

Presentation

EDS 03-E/O
DIN

Electro-magnetic pump

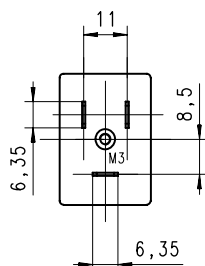
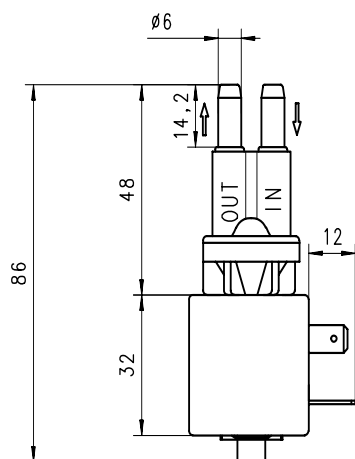

Electrical connection

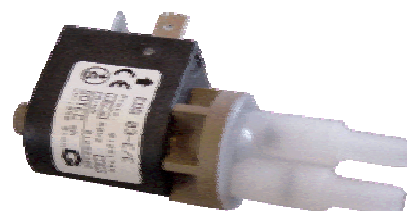
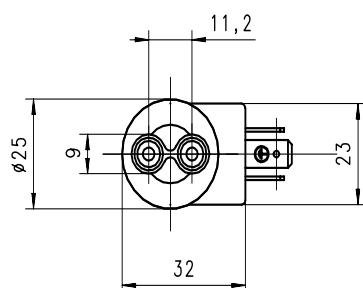

The membrane construction leads to the advantage to avoid any metallic parts contact with the liquid. The PVDF head and connectors accept almost all kind of liquids, the membrane and duckbills valves are in EPDM for the standard type.

This pump can run with or without liquid, and can be use for air transfer or sampling. It can be the solution when the presence of liquid to pump is not warranty.

This simple pump can replace very expensive peristaltic pumps, with the advantage to be maintenance free.

This pump, on request, can bear the UL security recognized mark category REUZ2, file Nr. E.213841.

Dimensions in millimeters (mm)

Hydraulic connection for soft tubing diameter from 4 to 5.5 (mm).

Application fields :

- Water removal without detection (air & liquid)
- Gas analyse appliances
- Medical and laboratory devices
- Additivation
- Fertilizer distribution
- Circulation, sampling of corrosive liquid



Performances tested with water :

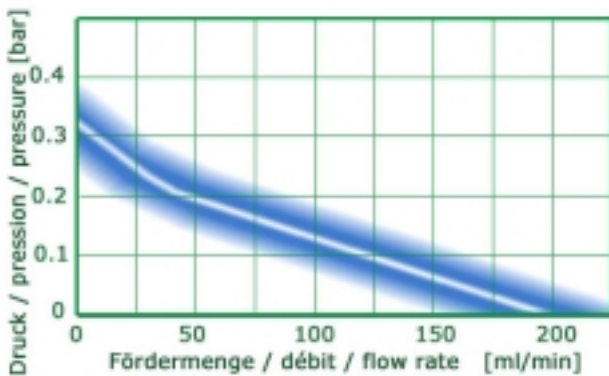

Nominal values, may vary with the power supply

Self-priming :

Maximum rated vertical lift : 1.5 [m]
Wet pumps have improved self-priming performance
! Maximum dry running time : 15 [min] !

Technical data

**EDS 03 –E/O
DIN**

Electro-magnetic pump

Materials in contact with the liquid :

Head & connectors : PVDF
Membrane : EPDM
Duckbills valves : EPDM

Special materials on request

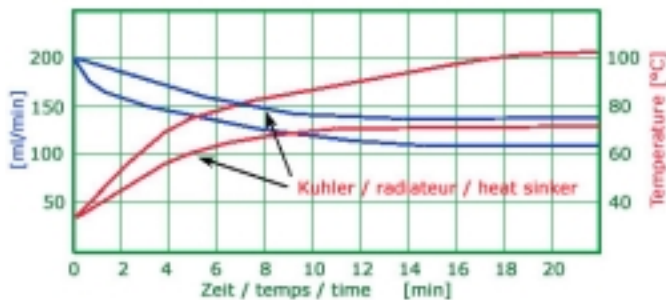

Heating & flow :

The coil (motor) is warming up when the pump is running. The temperature's rise increase the resistance of the coil and so decrease the performances. The surface temperature stabilized about 110°C and 70°C with a heat sinker when ambient & liquid temperature are about 25 [°C].

Electric wiring diagram

Fuse and diode are necessary

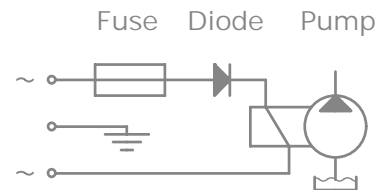

Please, refer to instruction manual for more installation details

Nominal rated data :

Rated voltage & frequency :

230/50, 110/60, 110/50, 24/50-60, 12/50-60 [VAC/Hz] diode rectified, specialty on request

Power consumption : maximum 18 [W]

Electrical connection : 3x 6.35/0.8 AMP style terminals, ISO/DIN 43650 11 [mm] form B

Coil insulation : class F (155°C), class H (180°C) for 110V (hot spot maximum allowed)

Insulation : Class I, require grounding (included : third terminal)

Operating cycle rate : continuous 100%ED @ 30°C

Dimension : 23/43.5/75 [mm] ***Weight :*** 100 [g]

Operating temperature range : liquid & ambient : -10°C to 50°C. Protect against freezing.

Noise level : dry run = ~42 [dB(A)], open flow = ~30 [dB(A)], max. pressure = ~27 [dB(A)]

Approvals : CE conform to 73/23/CEE , CB & S+ Cert. Nr. CH-1403, UL (US&CA) on request

EMC : conform to CE 89/336/CEE

Filter to mount before the pump: Mesh 200 [µm]

Viscosity range : 200...600 [mm²/s]