

ABTECH

TERMINAL BOXES

ELECTRICAL ENCLOSURES

HAZARDOUS AREA ENCLOSURES

SPECIAL PURPOSE ENCLOSURES

NOVAMAX INTL LLC - 8200 S Quebec St Suite A-3 Englewood, CO 80112
(303) 470-7226 Fax (303) 470-5773 Toll-Free 1-800-594-3380
www.novamaxinternational.com

**ENCLOSURE SPECIALISTS FOR THE ELECTRONICS, INSTRUMENTATION,
MARINE, OIL, GAS AND PETRO-CHEMICAL INDUSTRIES**

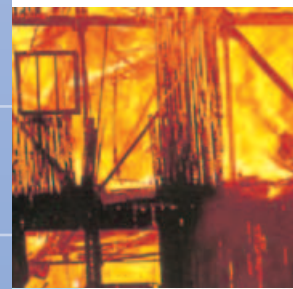

INTRODUCTION

Since the first Abtech sheet steel enclosure was manufactured in the 1970's the company has never lost sight of its goal, to become a leading supplier of quality electrical enclosures and junction boxes suitable for both industrial and hazardous area markets. This we believe has been achieved through innovation, market leading design, rigorous testing and adherence to quality.

In recent years Abtech have extended their range of enclosures to cope with ever increasing customer demands for unique solutions to their problems. These solutions include high voltage connection boxes (up to 15kV/3000Amps), high temperature junction boxes (up to 950°C for 3 hours) and IP68 enclosures (up to 120ft depth).

Abtech rose to the challenge when the Channel Tunnel was being constructed and produced over 12,500 junction boxes and emergency lighting actuators to the most exacting of standards. With the emphasis on reliability and safety, Abtech designed a solution that more than met the rigorous specification laid down by Eurotunnel.



As we move into the new millennium Abtech are once more expanding their range of products and services to help their customers cope with the need to meet ever-changing international standards. The entire hazardous area product range now complies with the latest European ATEX legislation and also AEx 'e' for the BPG, SX and ZAG ranges.

One of the innovations mentioned earlier is the Abtech 'Box Calculation Program' which calculates the number of terminals and cable entries which can be accommodated in an enclosure easily and quickly and with

the minimum of training and also carry out power dissipation calculations automatically.

Abtech also produce a hazardous area guide in poster form, which helps explain the various differences in certification requirements around the world, The program and poster are available free of charge to Abtech customers.

Abtech operate in the global market place as the nature of the Oil & Gas & Petrochemical industry demands and to meet this requirement Abtech operate at an International level.

With the head office based in Sheffield, England and factories and offices in Houston, Texas, Bünde, Germany; Singapore, Rio de Janeiro and a network of agents covering over 40 countries worldwide it can be seen that Abtech have the coverage to handle any project, no matter how large or diverse of location.

Indeed over the last 25 years, Abtech have been involved in many projects throughout the world and as can be seen from the project list (see inside back page) the client portfolio is indeed impressive.

The Abtech range of products are suitable for both industrial and hazardous area applications. Enclosures manufactured in stainless steel, mild steel, glass reinforced polyester, aluminium, polycarbonate and ABS are suitable for a wide range of industrial and OEM applications and Abtech have the facilities to modify the standard enclosure to meet the customer requirements. These services include machining, painting, silk screen printing, electro-polishing etc., and where required we can mould any of the plastic range of enclosures in a wide range of colours (subject to minimum order quantity).

The Abtech hazardous area range includes junction boxes and terminal connection enclosures and can be manufactured in stainless steel, mild steel, aluminium and GRP and suitable for use in both Zone 1 and Zone 2 areas and certified to the latest ATEX standards. Abtech also manufacture restricted breathing enclosures (EEx nR) which are capable of housing sparking and hot components and are suitable for use in Zone 2 areas and can often be a cost

effective alternative to flameproof enclosures (EEx d).

Whether the product is for an industrial or hazardous area application, Abtech place the utmost importance on quality as would be expected from a leading manufacturer.



The success of the company has been built on this dedication to total quality control and with over 25 years history of supply to the leading oil & gas companies throughout the world it is a policy that has been proven to work. With approvals such as BS EN ISO 9001:1994 and certification to British and CENELEC standards and approvals from certifying authorities in the UK, Canada and the USA, the company's commitment to quality ensures that safety is never compromised.

Technical support at Abtech begins long before the order is placed. Our dedicated sales staff both in the field and based at Sheffield can offer advice on enclosure type, terminal selection, cable entry placement and any other requirements that might dictate the eventual selection.

Technical assistance is also available at any time during the order process or indeed after the equipment is installed and Abtech staff will be only too happy to help with any questions you may have.



Registration No: 980141

ABTECH CONTENTS



Introduction	2
Box Calculator	3
Selection Chart	4
BPG Range Intro	5
BPG Range Accessories	6
BPG Range Terminal Contents	7
BPG Range Specifications	8
BPGA Range Specifications	12
PCS Range Specifications	13
SX Range Introduction	14
SX Range Accessories	15
SX Range Terminal Contents	16
SX Range Specifications	17
ZAG Range Introduction	21
ZAG Range Accessories	22
ZAG Range Terminal Contents	23
ZAG Range Specifications	24
ZP Range Introduction	28
ZP Range Accessories	29
ZP Range Terminal Contents	30
ZP Range Specifications	31
GPS Range Specifications	36
High Voltage Range Specifications	37
MJB Range Specifications	38
DPJB Range Specifications	39
HVJB Range Specifications	41
LR Range Specifications	43
Bus-Bar Range Specifications	44
Fire Survival Specifications	45
Technical Data	46
Abtech Projects	51



ABTECH

ENCLOSURE/MATERIAL SELECTION CHART

The following chart has been provided as a guide to help customers choose the correct enclosure or material suitable for certain defined areas of use. The chart is intended as a guide only and is based on the many years of experience gained by Abtech in providing enclosures into these areas of work.

ENCLOSURE TYPE	APPLICATION													
	Pharmaceutical Indoor	Chemical Plants Indoor	Chemical Plants Outdoor	Flour Mills Indoor	Flour Mills Outdoor	Paint Plants	Gas Bottle Storage	Sewage Plants	Ship Terminals	Ships Decks/ Deluge Areas	Airport Fuel Handling Equipment	Oil & Gas Platform/ FPSO/ Drilling Vessels Indoor	Oil & Gas Platform/ FPSO/ Drilling Vessels Outdoor	IP68 Applications
BPG	✓	✓	✓	✓	✓	✓	n	n	n	✓	✓	✓	✓	n
BPGC	✓	✓	✓	✓	✓	✓	n	n	n	✓	✓	✓	✓	n
MSX	n	n	n	n	n	n	n	l	✗	✗	l	n	✗	✗
SSX	✓	✓	✓	✓	✓	✓	✓	✓	✓	✓	✓	✓	✓	✓
ZAG R	n	n	n	✓	n	✓	n	l	l	l	n	n	l	✗
ZAG Painted	✓	✓	n	✓	✓	✓	n	n	l	l	n	✓	l	✗
ZAG Seawater	✓	✓	✓	✓	✓	✓	✓	✓	n	n	✓	✓	✓	n
ZP ABS	n	n	n	n	n	l	l	n	n	✗	✗	l	✗	✗
ZP PC	n	n	n	n	n	l	l	n	n	✗	✗	l	✗	✗

Note:

- The above table relates to the suitability of the enclosure material to withstand corrosion and degradation due to contamination and also the suitability with regard to the expected ingress protection (IP) rating of the enclosure.
- It is important when selecting an enclosure to consider fully the operating conditions that the enclosure will be exposed to. This is especially important for enclosures in hazardous areas as the enclosure forms an important part of the protection. Attention should be paid in particular to effects of corrosion and chemicals in the atmosphere and the likelihood of mechanical impact.
- For IP68 requirements it is important to choose a material that will not corrode and reduce the effectiveness of the seal arrangement. For example, a mild steel enclosure even if painted is unsuitable for long or even short term immersion in water as corrosion will quickly lead to porosity of the metal.
- Abtech staff will be happy to advise on the selection of suitable equipment.
 - ✓ Excellent suitability with long life expectancy
 - n A reasonable life span can be expected
 - l Can be used but may have a reduced lifespan
 - ✗ Not suitable

							
Quality Assurance	Printing	Accessories	Customising	Special Colours	Technical Assistance	Corrosion Resistant	Painting

ABTECH BPG RANGE

The BPG range comprises 16 sizes of enclosure manufactured in glass reinforced polyester. The polyester is highly resistant to contamination from oils, fats, aliphatic and aromatic carbohydrates, bacteria and enzymes. It is also suitable for LSOH (low smoke zero halogen) applications. This material gives excellent mechanical strength and life expectancy. The wall thickness is



sufficient to allow tapped entry holes to be machined in the walls of the enclosure and it provides a very good alternative to aluminium or cast iron.

Abtech mould the BPG range from SMC material rather than DMC which is the most common form of GRP. In this method the glass reinforcement takes the form of sheets rather than short strands. This gives much greater mechanical strength and also in the event of the enclosure being exposed to fire conditions the structure holds together even

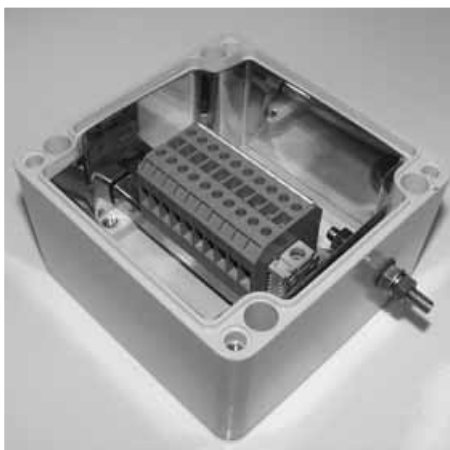

if the resin is depleted due to the elevated temperatures as demonstrated by the fact that the BPG range when fitted with ceramic terminals meets the requirements of IEC 331 (750°C for 3 hours) and also BS6387/1983 (950°C for 3 hours - flame only).

Due to the enclosure's labyrinth seal system, whereby the seal is protected from external

forces, the BPG enclosure has excellent ingress protection qualities which mean that the enclosure is tested to and passed IP66/67 and has also undergone and passed the Shell/ERA deluge test which was devised to adequately test enclosures and electrical equipment which is routinely subjected to ships decks conditions or fire deluge systems. The mounting holes, although contained within the profile of the enclosure, sit outside the seal and all external fasteners and fixings are manufactured from 316 grade stainless steel to ensure reliability.

The BPG range has many features which lend itself to a whole host of applications including both industrial and hazardous area, junction boxes, OEM applications, fire protection systems, tunnel wiring etc. The BPG range can be machined, drilled, tapped with various thread forms, painted and of course it can be moulded in a variety of colours which gives a much improved durability of colour over painting. The BPG range is also available carbon loaded (BPGC) which helps to reduce the

surface resistance of the material and consequently reduce the risk of spark from static build up.

Earthing can be accomplished by various means. External/internal earth stud which in turn can be connected to the terminal mounting rail or component mounting plate, an ECP (earth continuity plate) can be fitted around the inner walls to provide continuity for cable glands and various in rail mounted earth terminals or proprietary earth bars can be fitted inside the enclosure.

When fitted with a standard neoprene gasket the enclosure is suitable for ambient temperatures of -40°C to 80°C. Alternatively when fitted with an optional silicone gasket the temperature range is increased to -70°C to 130°C. For certified apparatus contact Sales Department for ambient operating temperatures.

The BPG and BPGC enclosures are suitable for use in hazardous areas and can be supplied with a number of certificates, specifically ATEX EEx 'e' to BS EN 50019 (zone 1 & 2) EEx 'nA' to BS EN50021 (zone 2) and NEMA 4X (CSA, UL & FM class 1, div 2). The BPG range can be supplied fitted with any component approved terminal to apparatus level or can be supplied empty as component approved for the clients own certification requirements.

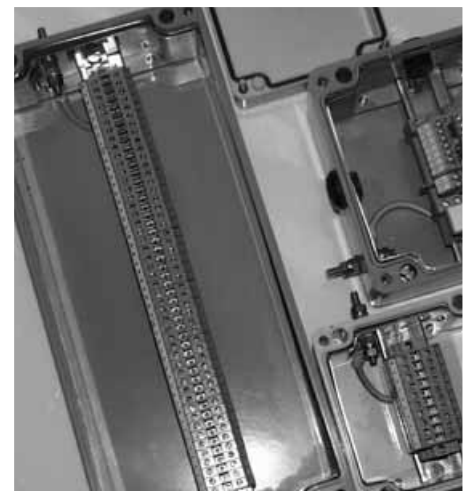

ABTECH BPG RANGE

ACCESSORIES

The following table is a list of the available accessories suitable for particular sizes of BPG enclosures. Care should be taken when ordering accessories for use with enclosures intended for hazardous areas to ensure that compliance with certification is retained.

SIZE	DIMENSIONS	C	Ex	ECP	ES	AL	TP	H	M	F	E	SIL	T	RFI
BPG1	80 x 75 x 55	n	n	-	-	n	n	n	n	-	-	n	n	n
BPG2	110 x 75 x 55	n	n	-	-	n	n	n	n	-	-	n	n	n
BPG3	160 x 75 x 55	n	n	-	-	n	n	n	n	-	-	n	n	n
BPG4	190 x 75 x 55	n	n	-	-	n	n	n	n	-	-	n	n	n
BPG4.5	190 x 75 x 75	n	n	-	-	n	n	n	n	-	-	n	n	n
BPG5	230 x 75 x 50	n	n	-	-	n	n	n	n	-	-	n	n	n
BPG6	122 x 120 x 90	n	n	n	n	n	n	n	n	n	n	n	n	n
BPG7	220 x 120 x 90	n	n	n	n	n	n	n	n	n	n	n	n	n
BPG8	160 x 160 x 90	n	n	n	n	n	n	n	n	n	n	n	n	n
BPG9	260 x 160 x 90	n	n	n	n	n	n	n	n	n	n	n	n	n
BPG10	360 x 160 x 90	n	n	n	n	n	n	n	n	n	n	n	n	n
BPG11	560 x 160 x 90	n	n	n	n	n	n	n	n	n	n	n	n	n
BPG12	255 x 250 x 120	n	n	n	n	n	n	n	n	n	n	n	n	n
BPG13	400 x 250 x 120	n	n	n	n	n	n	n	n	n	n	n	n	n
BPG14	600 x 250 x 120	n	n	n	n	n	n	n	n	n	n	n	n	n
BPG15	400 x 405 x 120	n	n	n	n	n	n	n	n	n	n	n	n	n

- C** - Carbon Loaded (gives surface tracking value of between 10⁶ and 10⁹ ohms).
- Ex** - Ex certified (may be component or apparatus certified - please specify requirements).
- RFI** - Fitted with RFI gasket and internally coated with RFI shielding (depending on gasket used, may reduce IP rating).
- SIL** - Silicone gasket giving greater temperature range (may also increase life when used in certain applications).

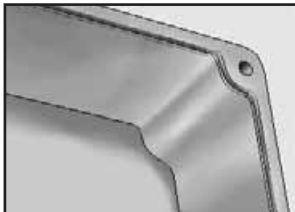

ECP
Copper earth continuity plate.
(Must also be fitted with earth stud)

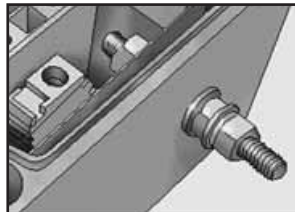

ES
Earth Stud.
(May be brass or stainless steel)

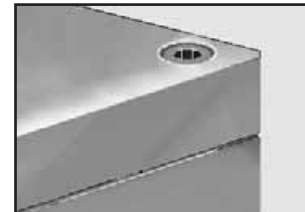

AL
Allen head fixing screw.
(Stainless steel grade 316)

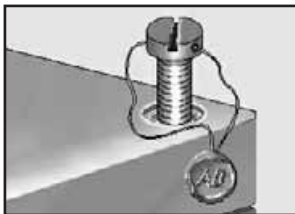

TP
Tamper-proof screws.
(Requires special tool for removal)

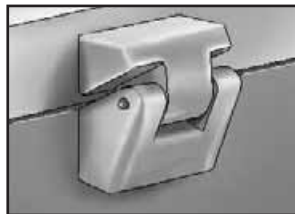

H
External hinges.

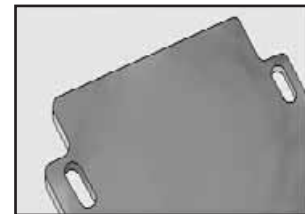

M
Component mounting plate.
(Tufnol - standard, steel - option)

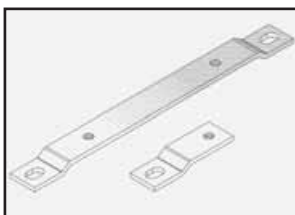

F
External mounting feet.
(Stainless steel grade 316)

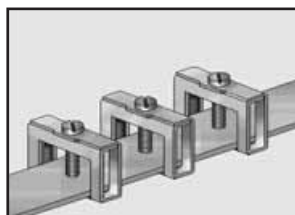

E
Internal earthing bar.
(Can be fitted with clamps)

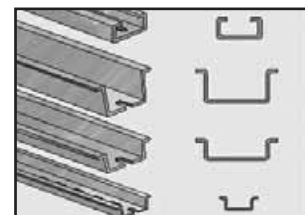

T
DIN standard mounting rail.
(TS15, TS32 or TS35, please specify)

ABTECH BPG RANGE

TERMINAL CONTENTS

The following tables are provided as a guide only. Due to space limitations only Weidmuller, Wago and Phoenix terminal populations are shown. Any component certified terminal may be fitted to the BPG range provided compliance with the terminal manufacturers component certificate is adhered to.

		WEIDMULLER											PHOENIX												
SIZE	Solid mm ²	4	4	4	6	6	4	6	10	16	16	501	4	4	4	4	4	4	4	10	10	16	16	35	
	Stranded mm ²	4	6	10	16	16	35	4	6	10	16	35	4	4	4	2.5	2.5	4	4	6	6	10	10	35	
CURRENT(A)		21	21	21	26	26	21	28	36	50	66	21	21	21	21	21	21	21	37	37	47	47	75		
TERMINAL TYPE																									
BOX TYPE	SCS POWER RATING (S)	NO. OF ROWS	BK 4 (4 way)	BK 6 (6 way)	BK 12 (12 way)	MK 6/4	MK 6/6	SAK 2.5	SAK 4	SAK 6N	SAK 10	SAK 16	SAK 35	GS/4 (4 way)	GS/6 (6 way)	GS/12 (12 way)	K 3	UK 3	K 5	UK 5	K 10	UK 10	K 16	UK 16	UK 35
			BPG 1	8.390	1	1	1	-	1	-	-	-	-	-	-	-	1	1	-	-	-	-	-	-	-
BPG 2	8.551	1	2	1	-	1	1	-	-	-	-	-	-	2	1	-	-	-	-	-	-	-	-	-	-
BPG 3	8.833	1	3	-	1	2	1	-	-	-	-	-	-	3	2	1	-	-	-	-	-	-	-	-	-
BPG 4	9.012	1	4	-	1	3	2	-	-	-	-	-	-	4	3	1	-	-	-	-	-	-	-	-	-
BPG 5	9.260	1	5	3	2	4	2	-	-	-	-	-	-	5	3	2	-	-	-	-	-	-	-	-	-
BPG 6	9.378	1	-	-	-	-	-	10	9	7	6	5	3	-	-	-	12	12	10	10	6	6	6	6	4
BPG 7	10.500	1	-	-	-	-	-	26	24	20	16	13	10	-	-	-	30	30	25	25	19	19	15	15	10
BPG 8	10.348	1	-	-	-	-	-	16	15	12	9	8	5	-	-	-	19	19	16	16	12	12	9	9	5
BPG 9	11.933	1	-	-	-	-	-	33	30	25	20	16	12	-	-	-	38	38	32	32	24	24	19	19	13
BPG 10	13.793	1	-	-	-	-	-	48	45	36	29	24	18	-	-	-	56	56	48	48	36	36	29	29	18
BPG 11	18.338	1	-	-	-	-	-	80	74	61	48	41	30	-	-	-	94	94	78	78	58	58	46	46	32
BPG 12	15.474	1	-	-	-	-	-	31	29	24	19	16	12	-	-	-	37	37	31	31	23	23	18	18	12
BPG 12	15.474	2	-	-	-	-	-	62	58	48	38	-	-	-	-	-	74	74	62	62	46	46	36	36	-
BPG 13	20.867	1	-	-	-	-	-	55	50	41	33	27	20	-	-	-	64	64	53	53	40	40	32	32	22
BPG 13	20.867	2	-	-	-	-	-	110	100	82	66	-	-	-	-	-	128	128	106	106	80	80	64	64	-
BPG 14	30.384	1	-	-	-	-	-	87	81	66	52	41	32	-	-	-	103	103	86	86	64	64	51	51	34
BPG 14	30.384	2	-	-	-	-	-	174	162	132	104	82	64	-	-	-	206	206	172	172	128	128	102	102	-
BPG 15	31.350	1	-	-	-	-	-	55	50	41	33	27	20	-	-	-	64	64	53	53	40	40	32	32	22
BPG 15	31.350	2	-	-	-	-	-	110	100	82	66	54	-	-	-	-	128	128	106	106	80	80	64	64	-
BPG 15	31.350	3	-	-	-	-	-	110	100	82	66	81	-	-	-	-	192	192	159	159	120	120	-	-	-

The above power ratings apply to an ambient operating temperature of 40°C. Reduced power ratings are available for ambient temperatures up to +65°C.

WAGO

SIZE	Stranded mm ²																		
	2.5	2.5	4	4	4	6	10	16	35	2.5	4	2.5	2.5	2.5	2.5	2.5			
CURRENT(A)		23	20	30	30	30	39	53	72	120	23	30	23	23	23	23			
TERMINAL TYPE																			
BOX TYPE	SCS POWER ratings (W)	NO. OF ROWS	280 - 991	280 - 699	281 - 691	281 - 991	281 - 695	282 - 691	284 - 691	283 - 691	285 - 691	280 - 698	281 - 693	264 - 120	264 - 220	264 2 Cond. Strip	264 4 Cond. Strip	262 2 Cond. Strip	262 4 Cond. Strip
			BPG 1	8.390	1	-	-	-	-	-	-	-	-	-	-	-	6	3	6
BPG 2	8.551	1	-	-	-	-	-	-	-	-	-	-	-	10	5	10	5	10	5
BPG 3	8.833	1	-	-	-	-	-	-	-	-	-	-	-	18	9	18	9	18	9
BPG 4	9.012	1	-	-	-	-	-	-	-	-	-	-	-	24	12	24	12	24	12
BPG 5	9.260	1	-	-	-	-	-	-	-	-	-	-	-	30	15	30	15	30	15
BPG 6	9.378	1	14	14	12	12	12	9	7	6	-	14	12	12	6	12	6	12	6
BPG 7	10.500	1	32	32	27	27	27	21	17	14	-	32	27	27	13	27	13	27	13
BPG 8	10.348	1	19	19	16	16	16	13	10	8	-	19	16	16	8	16	8	16	8
BPG 9	11.933	1	38	38	33	33	33	25	20	17	-	38	33	33	16	33	16	33	16
BPG 10	13.793	1	56	56	49	49	49	38	30	25	-	56	49	49	24	49	24	49	24
BPG 11	18.338	1	94	94	81	81	81	62	50	42	-	94	81	81	40	81	40	81	40
BPG 12	15.474	1	36	36	32	32	32	25	20	16	11	36	32	32	16	32	16	32	16
BPG 12	15.474	2	72	72	64	64	64	50	40	32	-	72	64	64	32	64	32	64	32
BPG 13	20.867	1	65	65	55	55	55	42	34	28	19	65	55	55	27	55	27	55	27
BPG 13	20.867	2	130	130	110	110	110	84	68	56	-	130	110	110	55	110	55	110	55
BPG 14	30.384	1	102	102	88	88	88	67	54	45	31	102	88	88	44	88	44	88	44
BPG 14	30.384	2	104	104	176	176	176	134	108	90	-	104	176	176	88	176	88	176	88
BPG 15	31.350	1	130	130	55	55	55	42	34	28	19	130	55	55	27	55	27	55	27
BPG 15	31.350	2	260	260	110	110	110	84	68	56	-	260	110	110	55	110	55	110	55
BPG 15	31.350	3	390	390	165	165	165	126	102	84	-	390	165	165	81	165	81	165	81

The above power ratings apply to an ambient operating temperature of 40°C. Reduced power ratings are available for ambient temperatures up to +65°C.

In some instances the terminal content shown above exceeds the power rating if all terminals are used at full certified current rating. In this instance steps should be taken to ensure the power rating is not exceeded.

The ABTECH BPG Ex range, when fitted with any component certified EEx'e' terminals, is Sira ATEX certified to EN 50 014 and EN 50 019. The empty enclosure is component certified and available for adding clients components subject to final approval by Sira or any recognised certifying authority. ABTECH have many years experience in the application of enclosures in hazardous areas and will be pleased to offer advice for any enclosure problems.

The power rating refers to the permitted power losses inside the enclosure. It is the responsibility of the user to keep power losses within these limits. Annex C2 of BS EN 50019 details the appropriate calculation method.

ABTECH BPG RANGE

BPG 1/BPGC 1

Size: 80 x 75 x 55mm
 Weight: 230g
 Rating: 8.390Watts

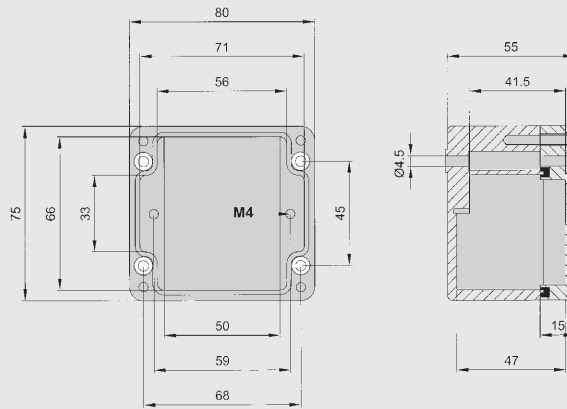

BPG 2/BPGC 2

Size: 110 x 75 x 55mm
 Weight: 230g
 Rating: 8.551Watts

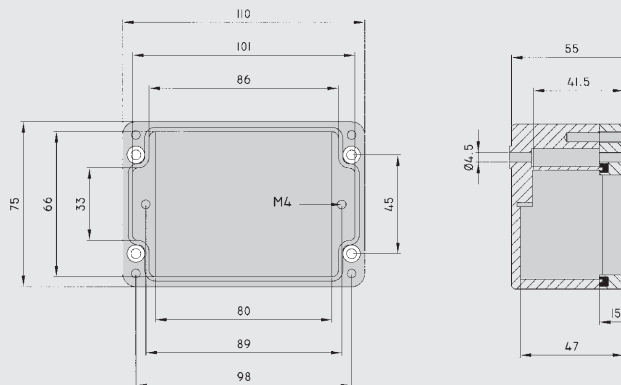

BPG 3/BPGC 3

Size: 160 x 75 x 55mm
 Weight: 405g
 Rating: 8.833Watts

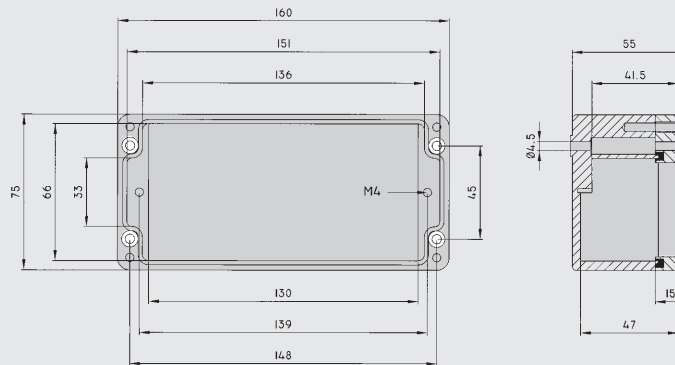

BPG 4/BPGC 4

Size: 190 x 75 x 55mm
 Weight: 450g
 Rating: 9.012Watts

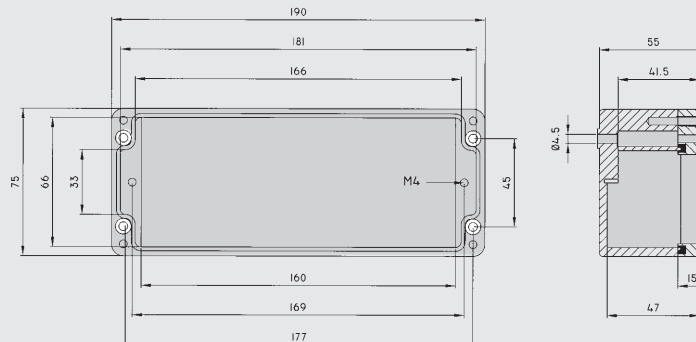

Glass reinforced polyester enclosures offering protection to IP 67. Temp range -40°C to 80°C with standard gasket or -70°C to 130°C with silicone gasket. Standard finish as moulded is RAL 7001 grey or black for BPGC. Can be moulded in variety of colours.



ABTECH BPG RANGE

BPG 5/BPGC 5

Size: 230 x 75 x 50mm

Weight: 529g

Rating: 9.260Watts

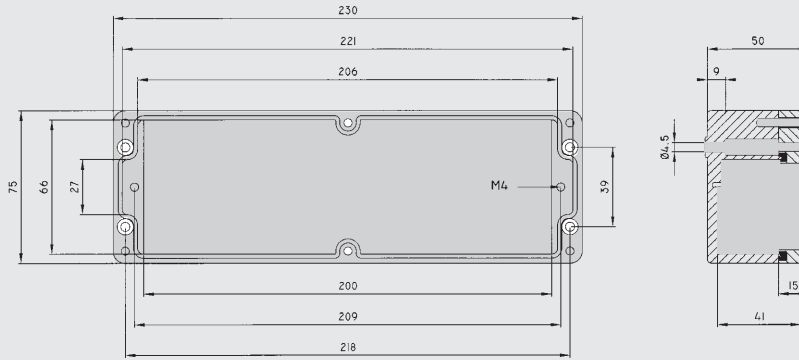

BPG 6/BPGC 6

Size: 122 x 120 x 90mm

Weight: 750g

Rating: 9.378Watts

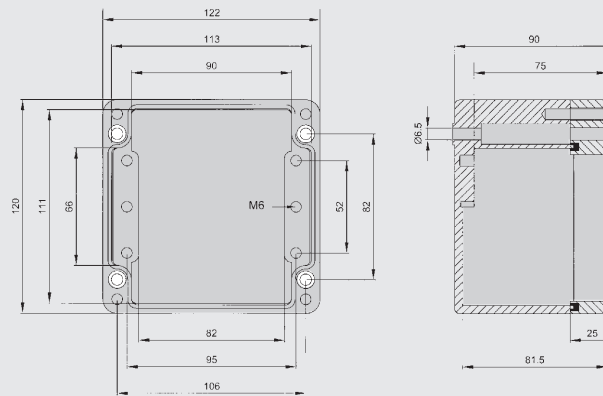

BPG 7/BPGC 7

Size: 220 x 120 x 90mm

Weight: 1060g

Rating: 10.500Watts

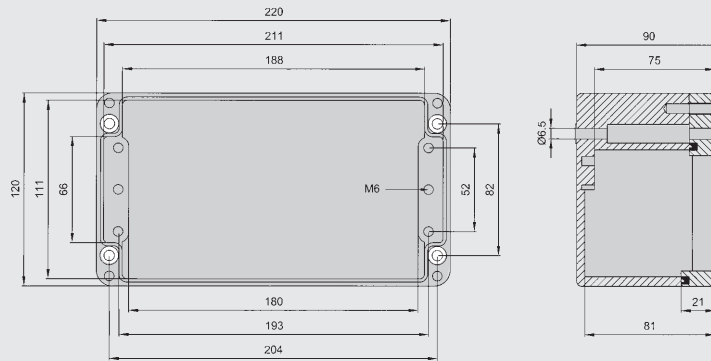

BPG 8/BPGC 8

Size: 160 x 160 x 90mm

Weight: 1130g

Rating: 10.348Watts

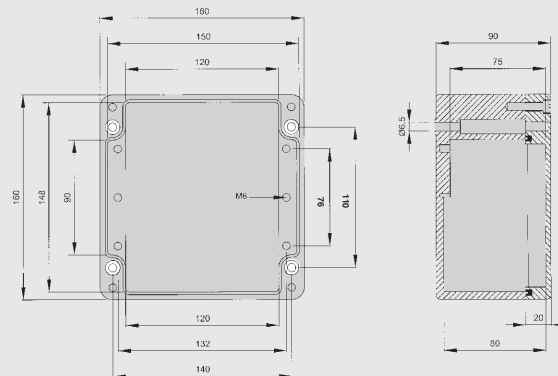

Glass reinforced polyester enclosures offering protection to IP 67. Temp range -40°C to 80°C with standard gasket or -70°C to 130°C with silicone gasket. Standard finish as moulded is RAL 7001 grey or black for BPGC. Can be moulded in variety of colours.



ABTECH BPG RANGE

BPG 9/BPGC 9

Size: 260 x 160 x 90mm

Weight: 1170g

Rating: 11.933Watts

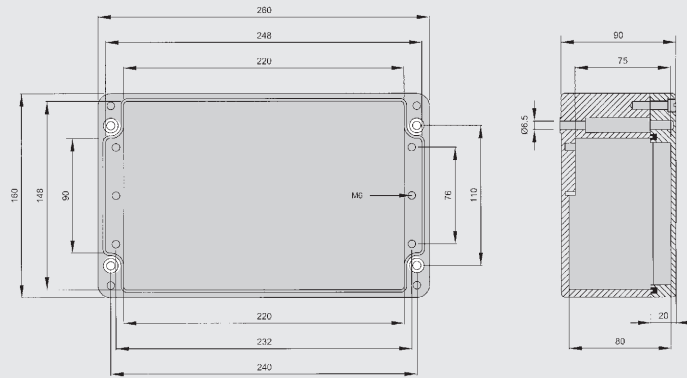

BPG 10/BPGC 10

Size: 360 x 160 x 90mm

Weight: 2150g

Rating: 13.793Watts

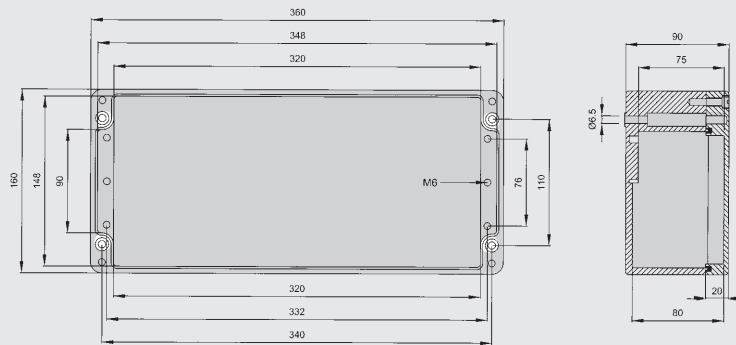

BPG 11/BPGC 11

Size: 560 x 160 x 90mm

Weight: 3200g

Rating: 18.338Watts

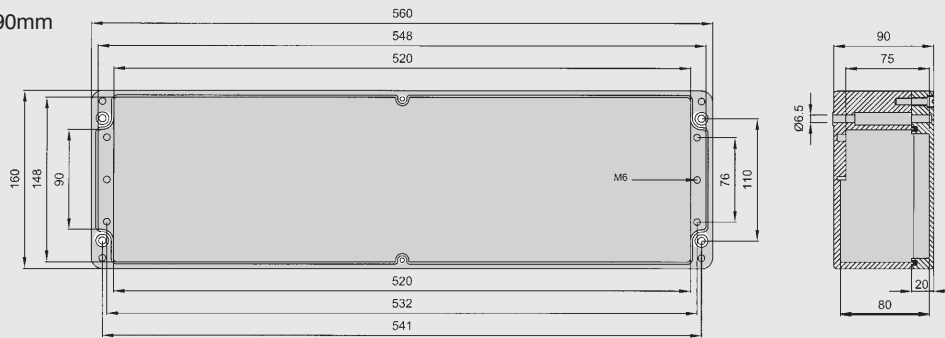

BPG 12/BPGC 12

Size: 255 x 250 x 120mm

Weight: 2656g

Rating: 15.474Watts

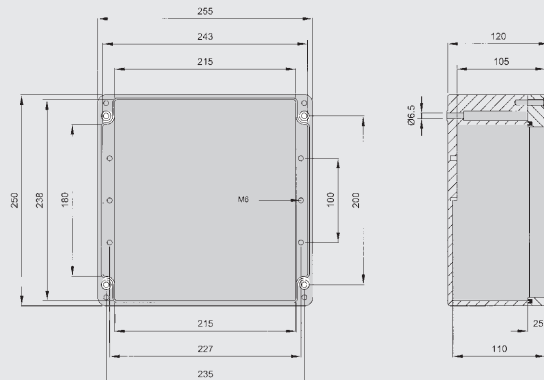

Glass reinforced polyester enclosures offering protection to IP 67. Temp range -40°C to 80°C with standard gasket or -70°C to 130°C with silicone gasket. Standard finish as moulded is RAL 7001 grey or black for BPGC. Can be moulded in variety of colours.



ABTECH BPG RANGE

BPG 13/BPGC 13

Size: 400 x 250 x 120mm

Weight: 3650g

Rating: 20.867Watts

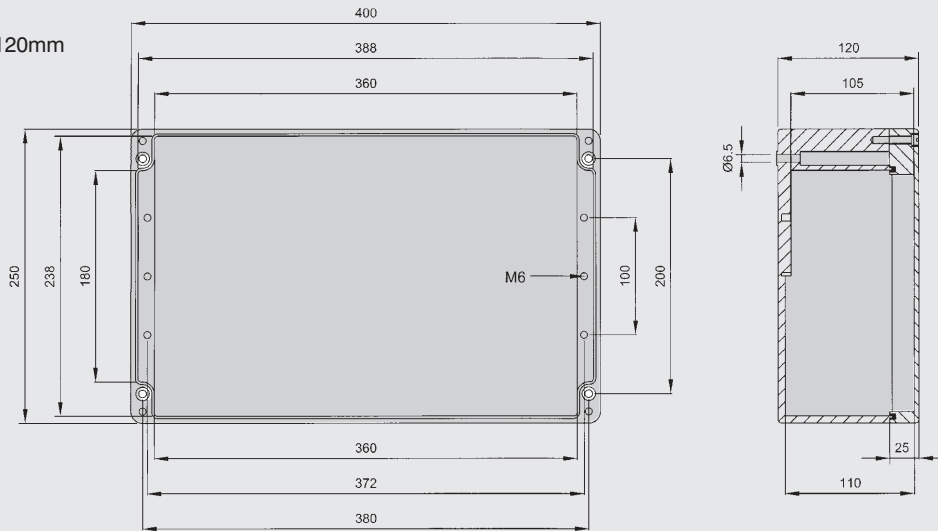

BPG 14/BPGC 14

Size: 600 x 250 x 120mm

Weight: 5235g

Rating: 30.384Watts

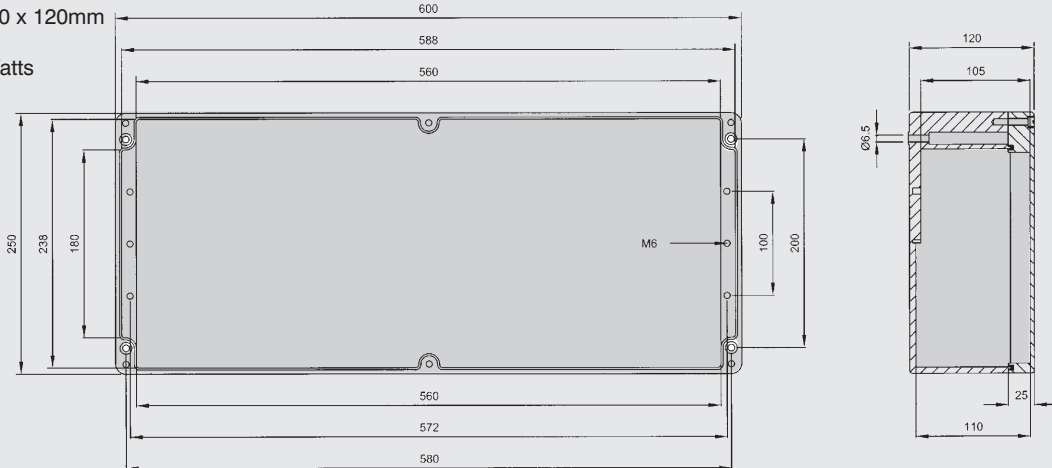

BPG 15/BPGC 15

Size: 400 x 405 x 120mm

Weight: 5580g

Rating: 31.350Watts

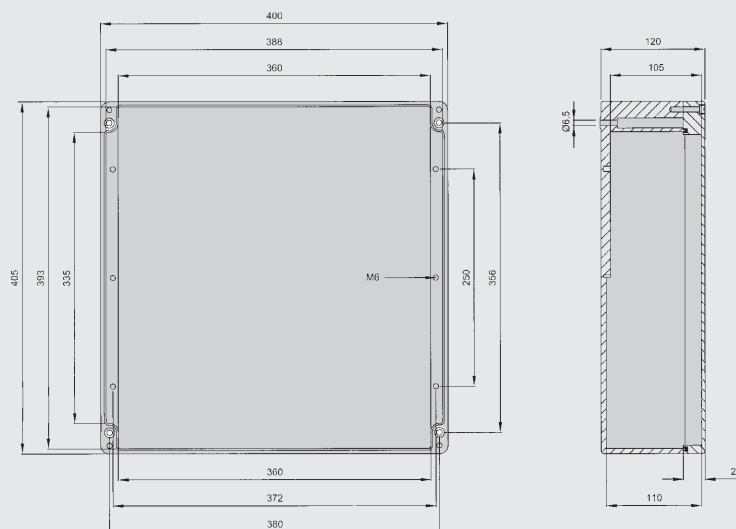

Glass reinforced polyester enclosures offering protection to IP 67. Temp range -40°C to 80°C with standard gasket or -70°C to 130°C with silicone gasket. Standard finish as moulded is RAL 7001 grey or black for BPGC. Can be moulded in variety of colours.



ABTECH BPGA RANGE

The Abtech BPGA range comprises three types of BPG enclosures in two different sizes which are available pre-assembled and readily available off the shelf. They are ideal for a range of uses such as lighting, power and instrument junction boxes.

They are manufactured in impact resistant glass reinforced polyester which has an ingress protection rating of IP66/67 and are Shell/ERA deluge tested.

The enclosures come equipped with terminals as shown in the table below, copper earth continuity plate and brass M6 internal/external earth stud. The enclosure is pre-drilled with four M20 tapped cable entries and is supplied complete with EEx 'e' certified blanking plugs. The range is ATEX certified EEx 'e' and is suitable for use in Category 2/Zone 1 and Category 3/Zone 2 areas according to EN 60079-14 with a working ambient temperature of between -20°C and +40°C.



SPECIFICATION	BPGA 120	BPGA 125	BPGA 160
Size (external)	122 x 120 x 90	122 x 120 x 90	160 x 160 x 90
Entries	4 x M20 (2 x A, 2 x C)	4 x M20 (2 x A, 2 x C)	4 x M20 (2 x A, 2 x C)
EEx 'e' Blanking plugs	3	3	3
Terminals	6 x SAK 2.5	1 x MK6/6 way	13 x SAK 2.5
Links	Linked in pairs	Linked in pairs	na
Int/Ext M6 earth stud	Yes	Yes	Yes
Copper earth continuity plate	Yes	Yes	Yes
Ingress Protection (IP)	IP 66/67	IP 66/67	IP 66/67
Shell/ERA Deluge tested	Yes	Yes	Yes

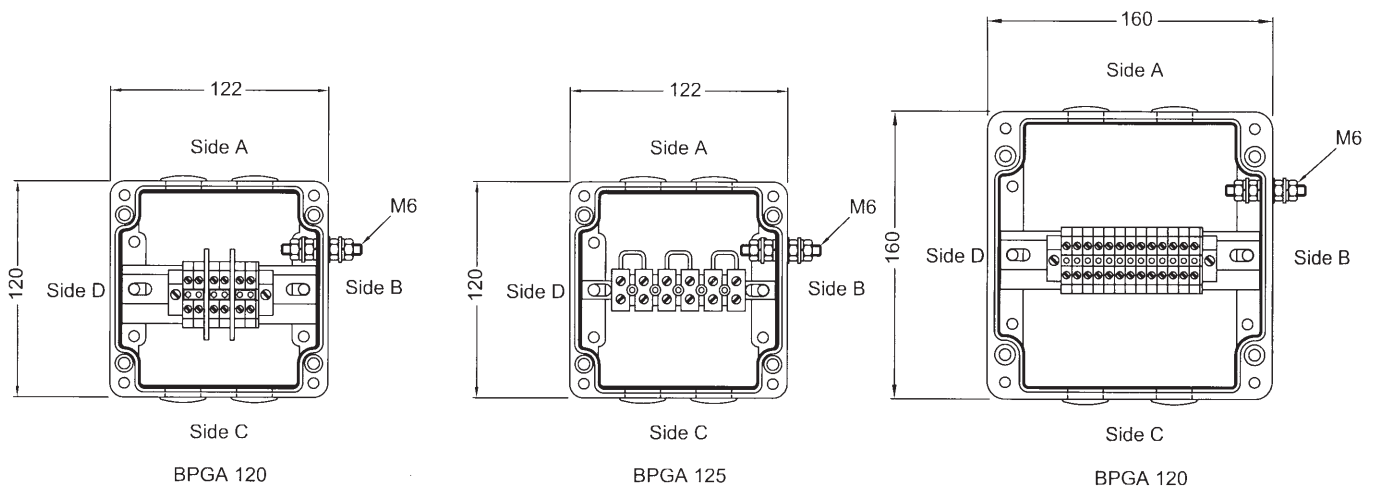

ABTECH PCS RANGE

The Abtech PCS range utilises the BPG range to house various push-buttons, switches, 2 position and 3 position selector switches, key switches and indicator lamps. The switching modules are available in the following:- two normally open contacts (2NO), two normally closed contacts (2NC) or one normally open contact plus one normally closed contact (1NC+1NO) in 2 different sized enclosures offering the choice of either, one operator in the PCS 8 or up to 4 operators in the PCS 9. The PCS 9 also has the advantage of a terminal strip inside the enclosure for wiring to the contacts. Ingress protection is IP66.

The enclosure is available in standard grey RAL7001 or carbon loaded black glass reinforced polyester. Cable entries can be specified by the customer on any of the four sides or on the base of the enclosure.

The range is ATEX certified EEx 'e' and is suitable for use in Category 2/Zone 1 and Category 3/Zone 2 areas according to EN 60079-14 with a working ambient temperature of between -20°C and +40°C. (other ambient temperatures are available)



SPECIFICATION	PCS 8		PCS 9	
Size (external)	160 x 160 x 90		260 x 160 x 90	
No. of Operators/lamps	1		Up to four	
Entries	as required		as required	
Terminals	na		up to 16 x 2.5mm ² terminals	
Links	na		as required	
Int/Ext M6 earth stud			available as option	
Copper earth continuity plate			available as option	
Ingress Protection (IP)			IP 66	
Contacts per operator			2 x NO, 2 x NC or 1 x NC + 1 x NO	
Rated operating voltage	250V	250V	110V	24V
Utilization category	AC 12	AC 15	DC 13	DC 13
Rated operating current	16A	10A	0.5A	1A
Lamp operating voltage	AC - 24V, 48V, 110V, 230V. DC - 24V, 48V.			
Power consumption	< 1W.			
Operators available	<p>Pushbutton - supplied with coloured inserts, green, red, yellow, white. Mushroom pushbutton - black. Emergency Stop pushbutton - red, marked 'NOTAUS EMERGENCY STOP' Locking mushroom pushbutton, can only be released with key. Keyswitch pushbutton, lockable in both 'in' and 'out' positions. Rotary selector switch available 2 way or 3 way, I - 0 or I - 0 - II. Lamps, multi LED colours - red, green, yellow, white, blue.</p>			

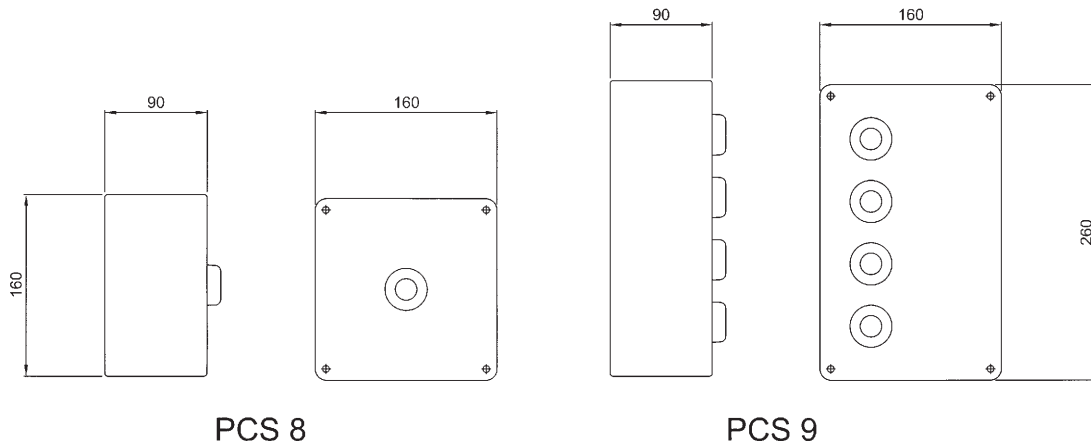

PCS 8

PCS 9

ABTECH SX RANGE

The SX range comprises 14 sizes of enclosure manufactured in either mild steel or stainless steel. Depending on the enclosure size they are available in standard depths of 140, 200 or 300mm and can be fitted with removable gland plates on any or all of the four sides. The mild steel version (MSX) is available with a number of paint options (most RAL colours available) and anti corrosion finishes and advice on this can be sought from Abtech.

The stainless steel range (SSX) is manufactured in 316 grade stainless steel to give the maximum environmental protection. The main body is manufactured from 2mm thick sheet and the mounting straps and gland plates from 3mm thick plate.

Cable entries can be drilled in the sides or through the gland plates, if fitted, or through the enclosure wall. Entries may also be drilled through the rear face of the enclosure (EEx versions also.)

The SX range was specifically designed to meet the rigours of the North Sea environment and is capable of achieving IP66 and IP67 and has also undergone and passed the Shell/ERA deluge test which was devised to adequately test enclosures and electrical equipment which is routinely subjected to ships decks conditions or fire deluge systems.

IP68 enclosures are also available for depths up to 120 ft to special order.

Another advantage of the SX range is that it is suitable for fire resistance applications

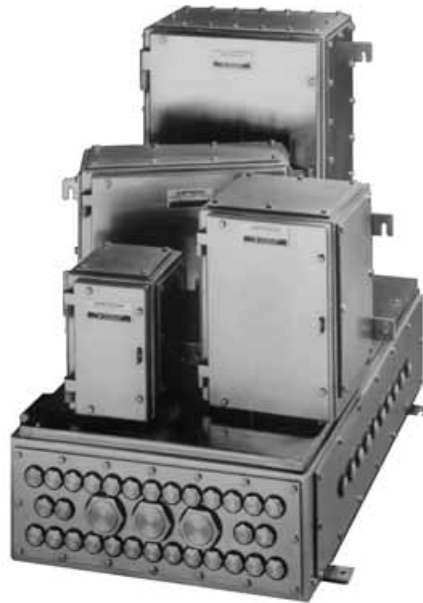

and when fitted with ceramic terminals meets the requirements of IEC 331 (750°C for 3 hours) and also BS6387/1983 (950°C for 3 hours).

Another important feature of the SX range is the door, which is held to the enclosure by at least 4 captive stainless steel screws, which also maintain the correct compression on the gasket. The hinges are solid block, machined oversize to enable the screws to control the closing of the door, not the hinge, its only function being to support the door when opened. The hinges allow easy removal of the door with only minimal opening required before removal (less than 10°).

The SX range has many features which lend itself to many applications, not least of which

is the ability to be constructed to almost any dimension due to its fabricated nature. This can also be applied to EEx enclosures where the certification allows oversize enclosures to be manufactured whilst retaining the next smallest sized enclosures' power rating. Other applications include junction boxes, both industrial and hazardous area, OEM applications, fire protection systems, tunnel wiring, IP68 applications, etc.

Earthing is accomplished by means of an external/internal earth stud fitted as standard which can be connected to the terminal mounting rail or component mounting plate and optionally earth studs can be fitted to the door and gland plates. Rail mounted earth terminals or proprietary earth bars can be fitted inside the enclosure and Abtech sales staff will be happy to advise on this.

When fitted with a standard neoprene gasket, the enclosure is suitable for ambient temperatures of -40°C to 80°C. Alternatively when fitted with an optional silicone gasket the temperature range is increased to -70°C to 130°C.

The SX range of enclosures are suitable for use in hazardous areas and can be supplied with a number of certificates. ATEX EEx 'e' to BS EN 50019 (Zone 1 & 2) EEx 'nA' to BS EN50021 (Zone 2) and NEMA 4X (CSA, UL & FM class 1, div 2). The SX range can be supplied fitted with any component approved terminal to apparatus level or can be supplied empty as component approved for the clients own certification requirements.

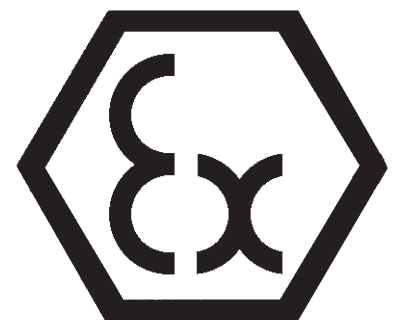

ABTECH SX RANGE

ACCESSORIES

The following table is a list of the available accessories suitable for particular standard sizes of SX enclosures. Care should be taken when ordering accessories for use with enclosures intended for hazardous areas to ensure that compliance with certification is retained.

Size	Dimensions	GP	DEPTH			EL	LB	ES	E	SIL	BD	TP	M	RFI
			140	200	300									
SX45	114 x 114 x 51	-	-	-	-	n	n	-	-	n	n	n	n	n
SX64	102 x 152 x 63	-	-	-	-	n	n	-	-	n	n	n	n	n
SX66	152 x 152 x 102	n	-	-	-	n	n	n	n	n	n	n	n	n
SX0	152 x 229	n	n	n	-	n	n	n	n	n	n	n	n	n
SX0.5	184 x 274	n	n	n	-	n	n	n	n	n	n	n	n	n
SX1	234 x 324	n	n	n	-	n	n	n	n	n	n	n	n	n
SX1.5	306 x 306	n	n	n	-	n	n	n	n	n	n	n	n	n
SX2	372 x 324	n	n	n	-	n	n	n	n	n	n	n	n	n
SX3	372 x 448	n	n	n	-	n	n	n	n	n	n	n	n	n
SX4	372 x 510	n	n	n	-	n	n	n	n	n	n	n	n	n
SX5	510 x 510	n	n	n	-	n	n	n	n	n	n	n	n	n
SX6	510 x 780	n	n	n	n	n	n	n	n	n	n	n	n	n
SX7	650 x 950	n	n	n	n	n	n	n	n	n	n	n	n	n
SX8	800 x 1250	n	n	n	n	n	n	n	n	n	n	n	n	n

All SX range enclosures are available manufactured in either mild steel - MSX or stainless steel grade 316 - SSX

All SX range enclosures are available Ex certified (component or apparatus certified - please specify requirements)

All SX range enclosures meet IP66/67. When fitted with gland plates the standard IP rating is IP66. IP67 available as option.

RFI - Fitted with RFI gasket (depending on gasket used, may reduce IP rating)

SIL - Silicone gasket giving greater temperature range. (may also increase life when used in certain applications)

EL - Electropolished external enclosure surface (stainless steel 316 only)

BD - Breather drain (IP66 stainless steel or plastic)

TP - Tamper-proof lid fixing screws



GP
Gland plates.
(Please specify sides to be fitted)

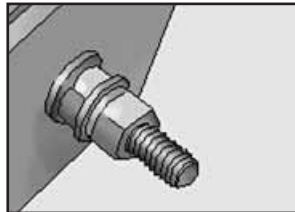

ES
Earth Stud fitted to door and gland plates. (If fitted - specify size req.)



LB
Label bracketed.
(Welded to door - specify size)

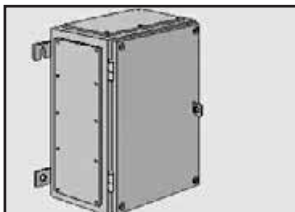

EL
Electro-polished.
(External surface 316 SS only)

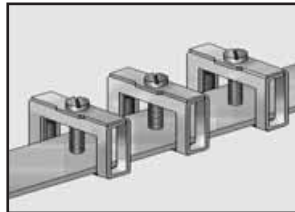

E
Internal earthing bar.
(Can be fitted with clamps)

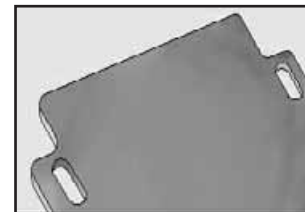

M
Component mounting plate.
(Steel or stainless steel)

ABTECH SX RANGE

TERMINAL CONTENTS

The following table is provided as a guide and due to space limitations in this brochure only Klippon, Wago and Phoenix terminal populations are shown. All Abtech enclosures are available empty or alternatively may be provided with terminals, entries, accessories and other electromechanical components.

		KLIPPON									PHOENIX					
SIZE	Solid mm ²	4	6	10	16	16		35	70	2.5	4	4	10	16	35	
	Stranded mm ²	4	4	6	10	16		35	70	2.5	2.5	4	6	10	35	
ATEX CURRENT(A)		15	22	26	37	47		75	-	-	-	-	-	-	-	
TERMINAL TYPE	SCS POWER RATING (S)	NO. OF ROWS	SAK2.5	SAK 6	SAK 6	SAK 10	SAK 16	SAK 35	SAK 70		UK 2.5B	UK 3	UK 5	UK 10	UK 16	UK 35
BOX TYPE																
SX 45		1	6	-	-	-	-	-	-	-	6	9	-	-	-	-
SX 64	10.258	1	14	12	10	8	-	-	-	-	14	16	10	8	-	-
SX 66	14.287	2	14	12	10	8	7	4	-	-	14	16	10	8	7	4
SX 0	19.874	1	17	15	13	10	8	6	3	-	17	20	13	10	8	6
SX 1	29.206	1	25	25	21	17	14	9	9	-	25	34	21	17	14	9
SX 1.5	32.284	2	48	48	40	32	13	8	9	-	48	68	40	32	13	8
SX 2	36.500	2	50	50	42	34	14	9	9	-	50	68	42	34	14	9
SX 3	42.289	2	90	90	76	60	25	16	12	-	90	118	76	60	25	16
SX 4	44.726	2	110	110	90	72	30	20	16	-	110	140	90	72	30	20
SX 5	50.238	3	165	165	135	108	60	40	32	-	165	210	135	108	60	40
SX 6	57.383	3	300	300	234	189	104	70	58	-	300	366	234	189	104	70
SX 7	68.000	3	408	408	300	240	198	132	100	-	408	465	300	240	198	132
SX 8	119.463	4	544	544	400	320	-	-	-	-	544	620	400	320	-	-
		5	915	845	685	550	455	244	230	-	915	1060	686	550	455	244
		6	1098	1014	822	660	-	-	-	-	1908	1272	822	660	-	-

The above power ratings apply to an ambient operating temperature of 40°C. Reduced power ratings are available for ambient temperatures up to +65°C.

		WAGO																						
BOX TYPE	SCS POWER ratings (W)	NO. OF ROWS	280 - 991														264 2 Cond. Strip		264 4 Cond. Strip		262 2 Cond. Strip		262 4 Cond. Strip	
			280 - 991	280 - 699	281 - 691	281 - 991	281 - 695	282 - 691	284 - 691	283 - 691	285 - 691	280 - 698	281 - 693	264 - 120	264 - 220	281 - 191	282 - 191	284 - 191	283 - 191	264 2 Cond. Strip	264 4 Cond. Strip	262 2 Cond. Strip	262 4 Cond. Strip	
SX 45	8.950	1	6	-	5	5	-	-	-	-	-	6	5	6	3	6	6	5	4	6	3	6	3	
SX 64	10.258	1	12	-	10	10	-	-	-	-	-	12	10	12	6	12	12	10	7	12	7	12	6	
SX 66	14.287	1	12	12	10	10	10	9	7	6	-	12	10	12	6	12	12	10	7	12	7	12	6	
SX 0	19.874	1	21	21	18	18	18	14	11	-	-	21	18	10	12	19	14	11	9*	20	12	20	9	
SX 1	29.206	1	35	35	29	29	29	23	18	15	10	35	29	32	19	30	23	18	18	32	19	32	15	
SX 1.5	32.284	2	70	70	58	58	58	46	36	30	10	70	58	64	38	60	46	36	36	64	38	64	30	
SX 2	36.500	2	70	70	58	58	58	46	36	30	10	70	58	64	38	60	56	36	36	64	38	64	30	
SX 3	42.289	2	118	118	100	100	100	78	62	52	18	118	100	106	64	104	78	62	62	106	64	106	52	
SX 4	44.726	2	140	140	120	120	120	92	74	62	21	140	120	126	76	124	92	74	74	126	76	126	62	
SX 5	50.238	3	210	210	180	180	180	138	111	93	42	210	180	189	114	186	138	111	111	189	114	189	93	
SX 6	57.383	3	360	360	300	300	300	130	189	156	74	360	300	15	192	318	240	189	189	315	192	314	156	
SX 7	68.000	3	450	450	390	390	390	300	240	195	135	450	390	405	240	390	300	240	240	405	240	405	195	
		4	600	600	520	520	520	400	320	260	-	600	520	540	320	520	400	320	320	540	320	540	260	
SX 8	119.463	5	1000	1000	875	875	875	675	550	450	252	1000	875	925	550	920	675	550	550	925	550	925	450	
		6	1200	1200	1050	1050	1050	810	660	540	-	1200	1050	1110	610	1104	810	660	660	1110	650	1110	540	

In some instances the terminal content shown above exceeds the power rating if all terminals are used at full certified current rating. In this instance steps should be taken to ensure the power rating is not exceeded.

The ABTECH SX Ex range, when fitted with any EEx'e' component approved terminals(1) is Sira certified to EN 50 014 and EN 50 019. The empty enclosure is component certified and available for adding clients components subject to final approval by Sira or any suitable notified body. ABTECH have many years experience in the application of enclosures in hazardous areas and will be pleased to offer advice for any enclosure problems.

(1) Any apparatus certified enclosure built after June 2003 must be fitted with ATEX approved terminals or components. Abtech sales staff can provide help and information on any aspect of certification in relation to Abtech enclosures.

The power rating refers to the permitted power losses inside the enclosure. It is the responsibility of the user to keep power losses within these limits. Annex C2 of BS EN 50019 details the appropriate calculation method.

ABTECH SX RANGE

MSX/SSX 45

Size: 114 x 114 x 51mm

Weight: 1.2kg

Rating: 8.950Watts

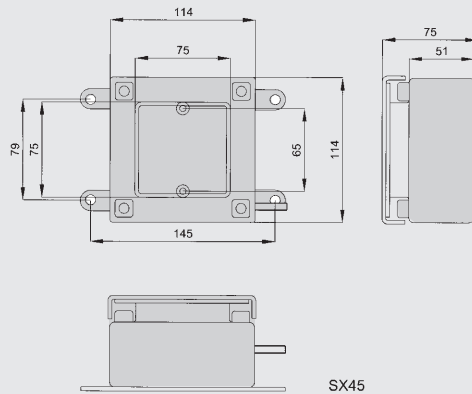

SX45

MSX/SSX 64

Size: 102 x 152 x 102mm

Weight: 1.5kg

Rating: 10.258Watts

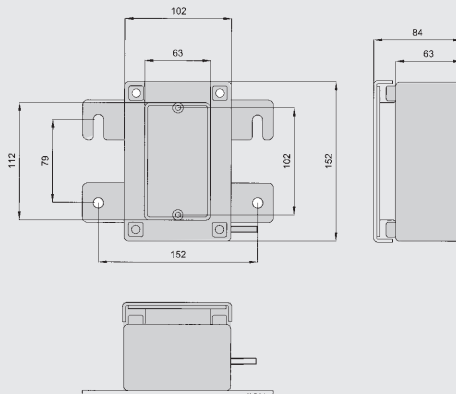

MSX/SSX 66

Size: 152 x 152 x 102mm

Weight: 2.2kg

Rating: 14.287Watts

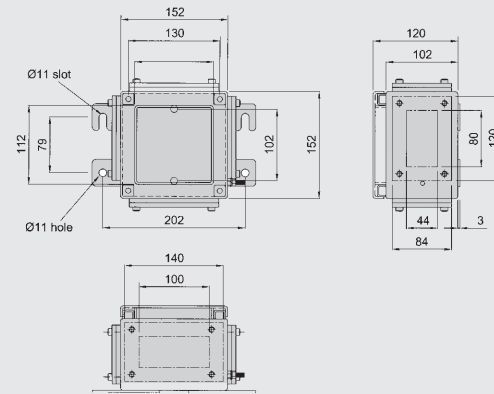

MSX/SSX 0

Size: 229 x 152 x 140/200mm

Weight: 3.2kg (140)

4.0kg (200)

Rating: 19.874Watts

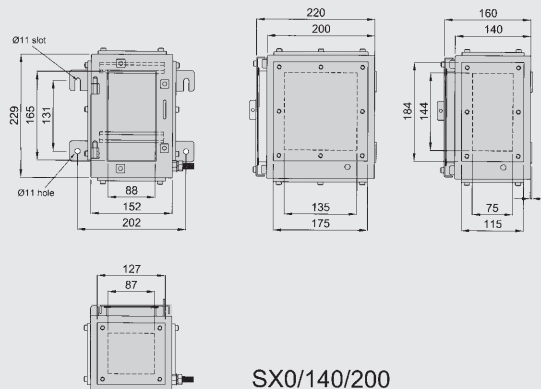

SX0/140/200

Mild steel or stainless steel enclosures offering protection to IP 67. Temp range -40°C to 80°C with standard gasket or -70°C to 130°C with silicone gasket.

Standard finish: MSX - Hammer finish grey epoxy polyester
SSX - Natural steel orbital matt finish



ABTECH SX RANGE

MSX/SSX 0.5

Size: 274 x 184 x 140/200mm

Weight: 5.0kg (140)

6.0kg (200)

Rating: 19.874Watts

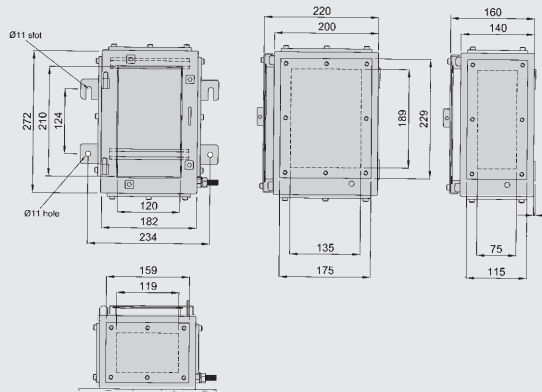

MSX/SSX 1

Size: 324 x 234 x 140/200mm

Weight: 6.3kg (140)

7.2kg (200)

Rating: 29.206Watts

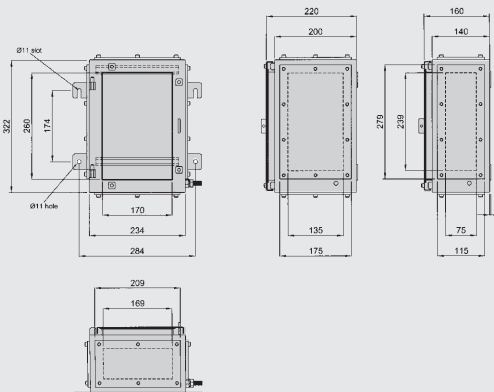

MSX/SSX 1.5

Size: 306 x 306 x 140/200mm

Weight: 7.3kg (140)

8.8kg (200)

Rating: 32.284Watts

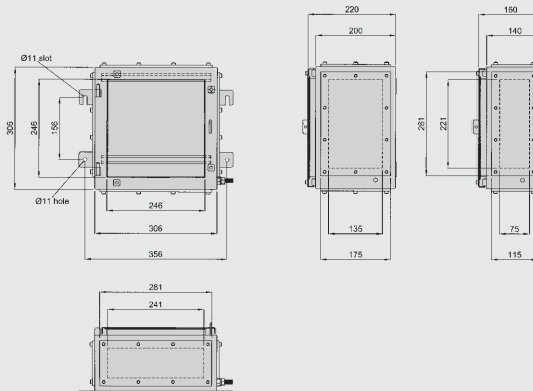

MSX/SSX 2

Size: 324 x 372 x 140/200mm

Weight: 9.5kg (140)

11.3kg (200)

Rating: 36.500Watts

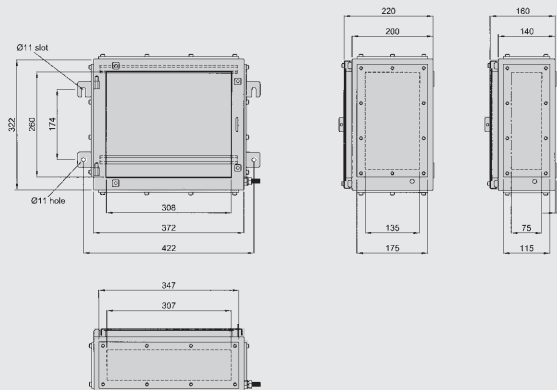

Mild steel or stainless steel enclosures offering protection to IP 67. Temp range -40°C to 80°C with standard gasket or -70°C to 130°C with silicone gasket.
Standard finish: MSX - Hammer finish grey epoxy polyester
SSX - Natural steel orbital matt finish



ABTECH SX RANGE

MSX/SSX 3

Size: 448 x 372 x 140/200mm

Weight: 11.3kg (140)

13.3kg (200)

Rating: 42.289Watts

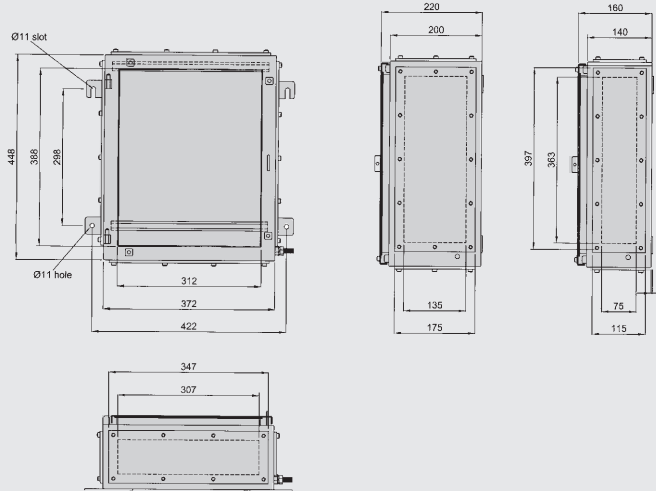

MSX/SSX 4

Size: 510 x 372 x 140/200mm

Weight: 12.7kg (140)

14.8kg (200)

Rating: 44.726Watts

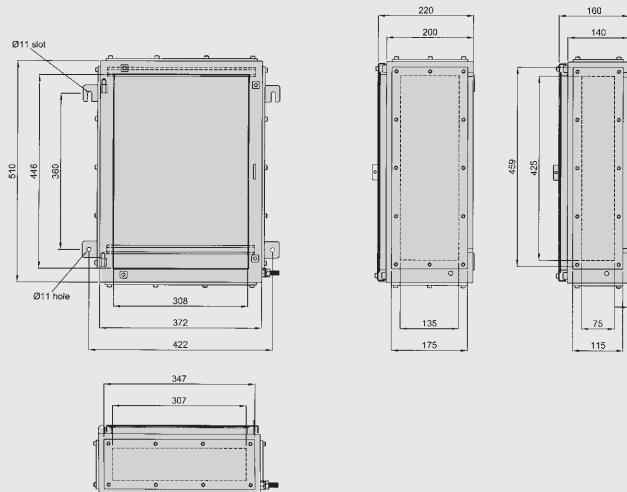

MSX/SSX 5

Size: 510 x 510 140/200mm

Weight: 17.0kg (140)

20.0kg (200)

Rating: 50.238Watts

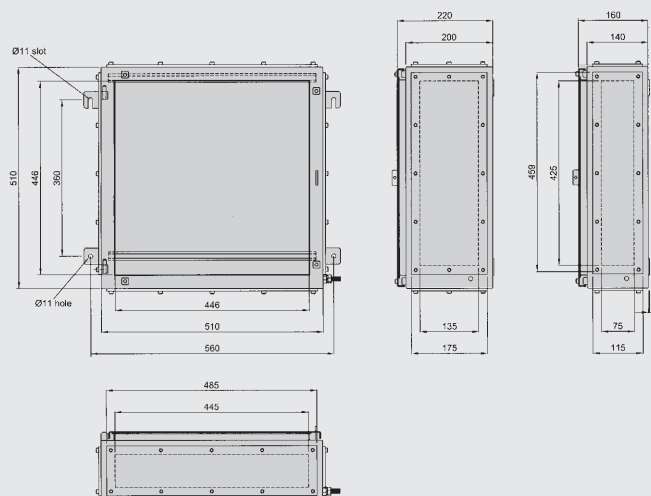

Mild steel or stainless steel enclosures offering protection to IP 67. Temp range -40°C to 80°C with standard gasket or -70°C to 130°C with silicone gasket.
Standard finish: MSX - Hammer finish grey epoxy polyester
SSX - Natural steel orbital matt finish



ABTECH SX RANGE

MSX/SSX 6

Size: 780 x 510 x 140/200/300mm

Weight: 24.0kg (140)

27.0kg (200)

32.0kg (300)

Rating: 57.383Watts

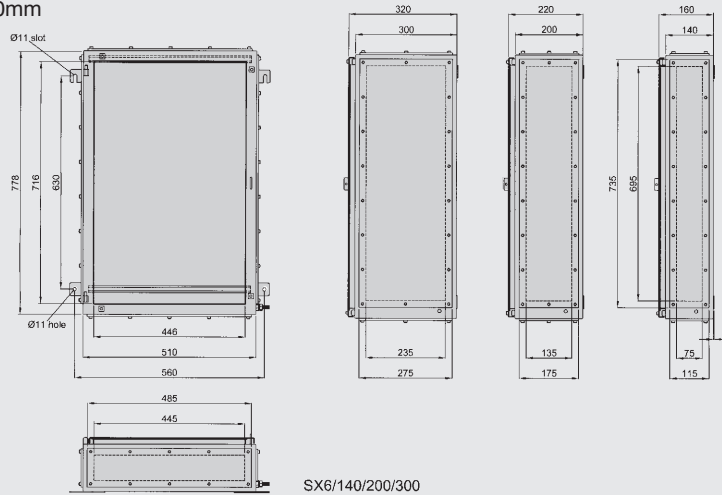

MSX/SSX 7

Size: 950 x 650 x 140/200/300mm

Weight: 35.0kg (140)

39.0kg (200)

52.0kg (300)

Rating: 68.000Watts

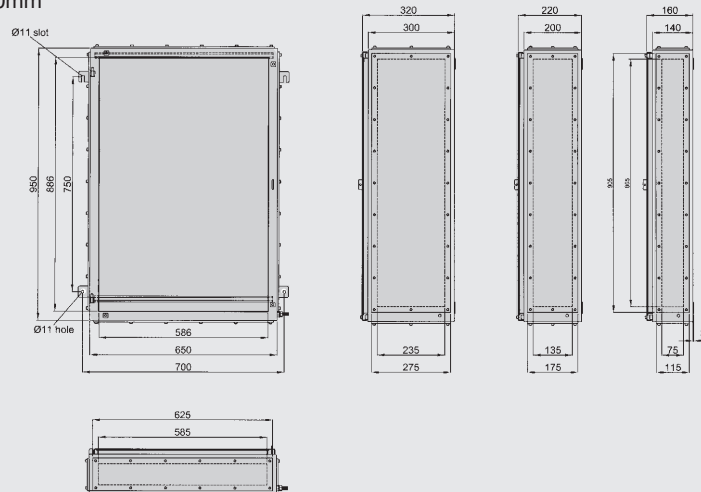

MSX/SSX 8

Size: 1250 x 800 x 140/200/300mm

Weight: 40.0kg (140)

45.0kg (200)

59.0kg (300)

Rating: 119.462Watts

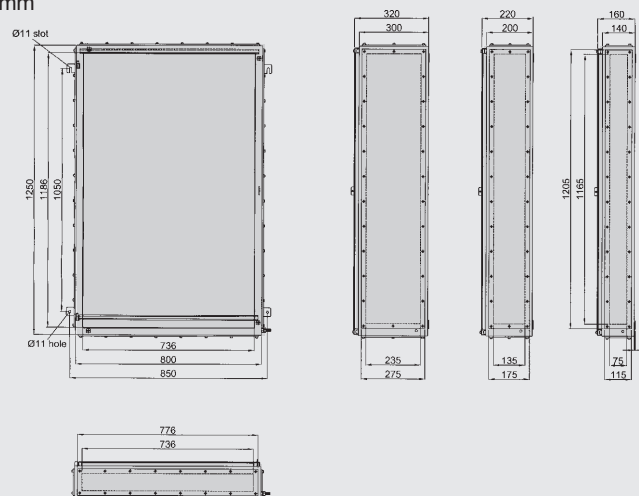

Mild steel or stainless steel enclosures offering protection to IP 67. Temp range -40°C to 80°C with standard gasket or -70°C to 130°C with silicone gasket.
Standard finish: MSX - Hammer finish grey epoxy polyester
SSX - Natural steel orbital matt finish

ISO
9002

ab
123

A



ABTECH ZAG RANGE

The ZAG range comprises 19 sizes of enclosure and are precision die cast in Al Si 12 grade (LM24) aluminium alloy. This is considered to be the most suitable grade of aluminium for maximum corrosion resistance especially in salt laden atmospheres. Additional optional protection methods such as Achrom, anodising and epoxy polyester painting coupled with the fitment of captive, 316 grade stainless steel, lid retaining screws further enhance the anti-corrosion properties of the enclosure. The wall thickness is sufficient to allow tapped entry holes to be machined in the walls or the base of the enclosure.

Due to the enclosure's labyrinth seal system, similar to that of the BPG range, whereby the seal is protected from external forces, the ZAG enclosure has excellent ingress protection qualities which mean that the enclosure is tested to and passed IP66/67.

The mounting holes although contained within the profile of the enclosure sit outside the seal and all external fasteners and fixings are manufactured from 316 grade stainless steel to ensure reliability. External stainless steel mounting feet are offered as an option.

The ZAG range has many features which lend itself to a whole host of applications including junction boxes, both industrial and hazardous area, and especially OEM applications, where the excellent machining



qualities of aluminium come to the fore. The ZAG range can be machined, drilled, tapped with various thread forms and it readily accepts most paint finishes and colours. The ZAG range is particularly suitable for engraving of instructions and decals and this method provides excellent durability. Silk screen printing is also available.

All of this can be achieved even in relatively small batches which make the ZAG range ideal for the small to medium size manufacturers who can achieve a custom enclosure economically.

Earthing can be accomplished by various means. External/internal stainless steel earth stud which in turn can be connected to the terminal mounting rail or component mounting plate and various rail mounted earth terminals or proprietary earth bars can be fitted inside the enclosure. Due to the fact that aluminium is an excellent conductor, earthing for cable glands is provided through contact with the enclosure wall with no further earthing necessary.

When fitted with a standard neoprene gasket the enclosure is suitable for ambient temperatures of -40°C to 80°C. Alternatively when fitted with an optional silicone gasket the temperature range is increased to -70°C to 130°C.

RFI screening is easily achieved using ZAG enclosures and the Abtech sales team can give advice on suitable RFI gaskets and finishing techniques which will provide optimum protection.

The ZAG enclosures are suitable for use in hazardous areas and can be supplied with a number of certificates. ATEX EEx 'e' to BS EN 50019 (zone 1 & 2) EEx 'nA' to BS EN50021 (zone 2) and NEMA 4X (CSA, UL & FM class 1, div 2). The ZAG range can be supplied fitted with any component approved terminal to apparatus level or can be supplied empty as component approved for the clients own certification requirements.

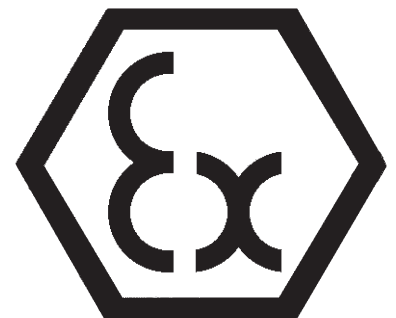

ABTECH ZAG RANGE

ACCESSORIES

The following table is a list of the available accessories suitable for particular sizes of BPG enclosures. Care should be taken when ordering accessories for use with enclosures intended for hazardous areas to ensure that compliance with certification is retained.

Size	Dimensions	R	Ex	AC	ES	AL	TP	H	M	F	E	SIL	T	RFI
ZAG 1	50x 45 x 30	n	-	n	-	n	n	-	-	-	-	n	n	n
ZAG 2	58 x 64 x 36	n	n	-	-	n	n	-	n	-	-	n	n	n
ZAG 3	98 x 64 x 36	n	n	n	n	n	n	-	n	-	-	n	n	n
ZAG 4	150 x 64 x 36	n	n	n	n	n	n	-	n	n	-	n	n	n
ZAG 5	75 x 80 x 57	n	n	n	n	n	n	n	n	n	-	n	n	n
ZAG 6	125 x 80 x 57	n	n	-	n	n	n	n	n	n	-	n	n	n
ZAG 7	175 x 80 x 57	n	n	n	n	n	n	n	n	n	-	n	n	n
ZAG 8	250 x 80 x 54	n	n	n	n	n	n	n	n	n	-	n	n	n
ZAG 9	122 x 120 x 80	n	n	n	n	n	n	n	n	n	n	n	n	n
ZAG 9/9	122 x 120 x 90	n	n	n	n	n	n	n	n	n	n	n	n	n
ZAG 10	220 x 120 x 80	n	n	n	n	n	n	n	n	n	n	n	n	n
ZAG 10/9	220 x 120 x 90	n	n	n	n	n	n	n	n	n	n	n	n	n
ZAG 11	160 x 160 x 90	n	n	n	n	n	n	n	n	n	n	n	n	n
ZAG 12	260 x 160 x 90	n	n	n	n	n	n	n	n	n	n	n	n	n
ZAG 13	360 x 160 x 90	n	n	n	n	n	n	n	n	n	n	n	n	n
ZAG 14	560 x 160 x 90	n	n	n	n	n	n	n	n	n	n	n	n	n
ZAG 15	200 x 230 x 110	n	n	n	n	n	n	n	n	n	n	n	n	n
ZAG 16	330 x 230 x 110	n	n	n	n	n	n	n	n	n	n	n	n	n

- R** - Raw (Unpainted natural finish)
- Ex** - Ex certified (maybe component or apparatus certified - please specify requirements)
- RFI** - Fitted with RFI gasket (depending on gasket used, may reduce IP rating)
- SIL** - Silicone gasket giving greater temperature range. (may also increase life when used in certain applications)



AC
Alochrome surface treatment.
(Added corrosion resistance)

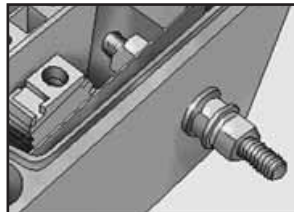

ES
Earth Stud.
(May be brass or stainless steel)

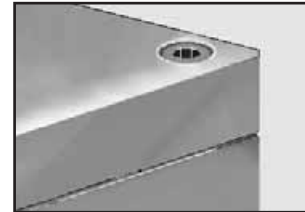

AL
Allen head fixing screw.
(Stainless steel grade 316)

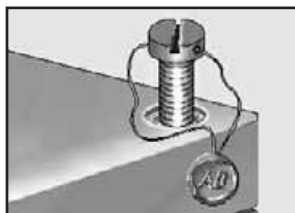

TP
Tamper-proof screws.
(Requires special tool for removal)

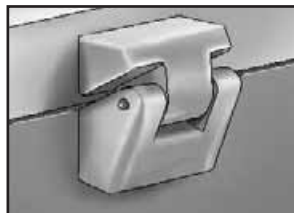

H
External hinges.

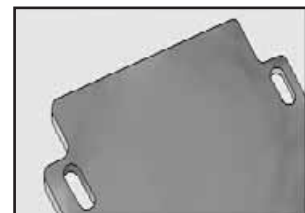

M
Component mounting plate.
(Tufnol - standard; steel - option)

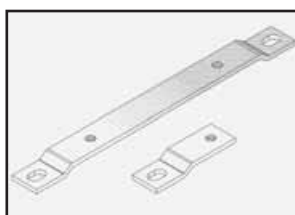

F
External mounting feet.
(Stainless steel grade 316)

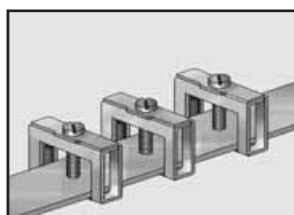

E
Internal earthing bar.
(Can be fitted with clamps)

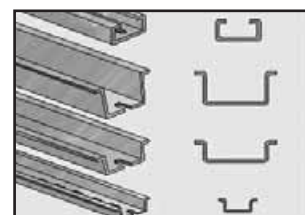

T
DIN standard mounting rail.
(TS15, TS32 or TS35, please specify)

ABTECH ZAG RANGE

TERMINAL CONTENTS

The following tables are provided as a guide only. Due to space limitations only Weidmuller, Wago and Phoenix terminal populations are shown. Any component certified terminal may be fitted to the ZAG range provided compliance with the terminal manufacturers component certificate is adhered to.

		KLIPPON											PHOENIX													
SIZE	Solid mm ²	4	4	4	6	6	4	6	10	16	16	50	4	4	4	4	4	4	4	10	10	16	16	35		
	Stranded mm ²	4	6	10	16	16	35	4	6	10	16	35	4	4	4	2.5	2.5	4	4	6	6	10	10	35		
CURRENT(A)		21	21	21	26	26	21	28	36	50	66	99	21	21	21	21	21	21	21	37	37	47	47	75		
TERMINAL TYPE	SCS POWER RATING (W)	NO. OF ROWS	BK 4 (4 way)	BK 6 (6 way)	BK 12 (12 way)	MKG/3	MKG 6/4	MKG 6/6	SAK 2.5	SAK 4	SAK 6N	SAK 10	SAK 16	SAK 35	GS/4 (4 way)	GS/6 (6 way)	GS/12 (12 way)	K 3	UK 3	K 5	UK 5	K 10	UK 10	K 16	UK 16	UK 35
BOX TYPE	SCS POWER RATING (W)	NO. OF ROWS	BK 4 (4 way)	BK 6 (6 way)	BK 12 (12 way)	MKG/3	MKG 6/4	MKG 6/6	SAK 2.5	SAK 4	SAK 6N	SAK 10	SAK 16	SAK 35	GS/4 (4 way)	GS/6 (6 way)	GS/12 (12 way)	K 3	UK 3	K 5	UK 5	K 10	UK 10	K 16	UK 16	UK 35
ZAG 1	N/A	1	-	-	-	-	-	-	-	-	-	-	-	-	-	-	-	-	-	-	-	-	-	-	-	-
ZAG 2	0.900	1	1	-	-	1	-	-	-	-	-	-	-	-	1	-	-	-	-	-	-	-	-	-	-	-
ZAG 3	1.200	1	1	1	-	1	1	1	-	-	-	-	-	-	1	1	-	-	-	-	-	-	-	-	-	-
ZAG 4	1.700	1	3	2	1	3	2	1	-	-	-	-	-	-	3	2	1	-	-	-	-	-	-	-	-	-
ZAG 5	1.500	1	1	1	-	1	1	-	-	-	-	-	-	-	1	1	-	-	-	-	-	-	-	-	-	-
ZAG 6	2.200	1	2	1	1	2	1	1	-	-	-	-	-	-	2	1	1	-	-	-	-	-	-	-	-	-
ZAG 7	2.900	1	3	2	1	3	2	1	-	-	-	-	-	-	3	2	1	-	-	-	-	-	-	-	-	-
ZAG 8	2.900	1	4	2	2	4	2	2	-	-	-	-	-	-	7	4	2	-	-	-	-	-	-	-	-	-
ZAG 9 & 9/9	3.400	1	-	-	-	-	-	-	10	9	7	6	5	3	-	-	-	12	12	10	10	7	7	6	6	4
ZAG 10 & 10/9	5.400	1	-	-	-	-	-	-	26	24	20	16	13	10	-	-	-	31	31	26	26	19	19	15	15	10
ZAG 11	5.400	1	-	-	-	-	-	-	16	15	12	9	8	5	-	-	-	19	19	16	16	12	12	9	9	5
ZAG 12	8.000	1	-	-	-	-	-	-	33	30	25	20	16	12	-	-	-	38	38	32	32	24	24	19	19	13
ZAG 13	10.400	1	-	-	-	-	-	-	48	45	36	29	24	18	-	-	-	56	56	48	48	36	36	29	29	18
ZAG 14	10.400	1	-	-	-	-	-	-	80	74	61	48	41	30	-	-	-	94	94	78	78	58	58	46	46	32
ZAG 15	9.500	1	-	-	-	-	-	-	22	20	17	13	11	8	-	-	-	94	94	78	78	58	58	46	46	32
ZAG 15	9.500	2	-	-	-	-	-	-	44	40	34	26	22	16	-	-	-	64	64	53	53	40	40	32	32	22
ZAG 16	14.000	1	-	-	-	-	-	-	43	40	32	26	22	15	-	-	-	206	206	172	172	128	128	102	102	-
ZAG 16	14.000	2	-	-	-	-	-	-	86	80	64	52	44	30	-	-	-	64	64	53	53	40	40	32	32	22
ZAG 21	5.400	1	-	-	-	-	-	-	86	80	64	52	44	30	-	-	-	64	64	53	53	40	40	32	32	22

The above power ratings apply to an ambient operating temperature of 40°C.

		WAGO																						
SIZE	Stranded mm ²	2.5	2.5	4	4	4	6	10	16	35	2.5	4	2.5	2.5	2.5	2.5	2.5	2.5	2.5	2.5	2.5	2.5	2.5	2.5
	CURRENT(A)	23	20	30	30	30	39	53	72	120	23	30	23	23	23	23	23	23	23	23	23	23	23	23
BOX TYPE	SCS POWER ratings (W)	NO. OF ROWS	280 - 991	280 - 699	281 - 691	281 - 991	281 - 695	282 - 691	284 - 691	283 - 691	285 - 691	280 - 698	281 - 693	264 - 120	264 - 220	264 2 Cond. Strip	264 4 Cond. Strip	262 2 Cond. Strip	262 4 Cond. Strip					
ZAG 1	N/A	1	-	-	-	-	-	-	-	-	-	-	-	-	6	3	6	3	6	3				
ZAG 2	0.900	1	-	-	-	-	-	-	-	-	-	-	-	-	10	5	10	5	10	5				
ZAG 3	1.200	1	-	-	-	-	-	-	-	-	-	-	-	-	18	9	18	9	18	9				
ZAG 4	1.700	1	-	-	-	-	-	-	-	-	-	-	-	-	24	12	24	12	24	12				
ZAG 5	1.500	1	-	-	-	-	-	-	-	-	-	-	-	-	30	15	30	15	30	15				
ZAG 6	2.200	1	14	14	12	12	12	9	7	6	-	14	12	12	6	12	6	12	6					
ZAG 7	2.900	1	32	32	27	27	27	21	17	14	-	32	27	27	13	27	13	27	13					
ZAG 8	2.900	1	19	19	16	16	16	13	10	8	-	19	16	16	8	16	8	16	8					
ZAG 9 & 9/9	3.400	1	38	38	33	33	33	25	20	17	-	38	33	33	16	33	16	33	16					
ZAG 10 & 10/9	5.400	1	56	56	49	49	49	38	30	25	-	56	49	49	24	49	24	49	24					
ZAG 11	5.400	1	94	94	81	81	81	62	50	42	-	94	81	81	40	81	40	81	40					
ZAG 12	8.000	1	36	36	32	32	32	25	20	16	11	36	32	32	16	32	16	32	16					
ZAG 13	10.400	1	72	72	64	64	64	50	40	32	-	72	64	64	32	64	32	64	32					
ZAG 14	10.400	1	65	65	55	55	55	42	34	28	19	65	55	55	27	55	27	55	27					
ZAG 15	9.500	1	130	130	110	110	110	84	68	56	-	130	110	110	55	110	55	110	55					
ZAG 15	9.500	2	102	102	88	88	88	67	54	45	31	102	88	88	44	88	44	88	44					
ZAG 16	14.000	1	104	104	176	176	176	134	108	90	-	104	176	176	88	176	88	176	88					
ZAG 16	14.000	2	130	130	55	55	55	42	34	28	19	130	55	55	27	55	27	55	27					
ZAG 21	5.400	1	260	260	110	110	110	84	68	56	-	260	110	110	55	110	55	110	55					

The above power ratings apply to an ambient operating temperature of 40°C.

In some instances the terminal content shown above exceeds the power rating if all terminals are used at full certified current rating. In this instance steps should be taken to ensure the power rating is not exceeded.

The ABTECH ZAG Ex range, when fitted with any ATEX component certified EEx'e' terminals, is Sira ATEX certified to EN 50 014 and EN 50 019. The empty enclosure is component certified and available for adding clients components subject to final approval by Sira or any suitably notified body. ABTECH have many years experience in the application of enclosures for use in hazardous areas and will be pleased to offer advice for any enclosure problems.

The power rating refers to the permitted power losses inside the enclosure. It is the responsibility of the user to keep power losses within these limits. Annex C2 of BS EN 50019 details the appropriate calculation method.

ABTECH ZAG RANGE

ZAG 1

Size: 50 x 45 x 30mm
Weight: 74g

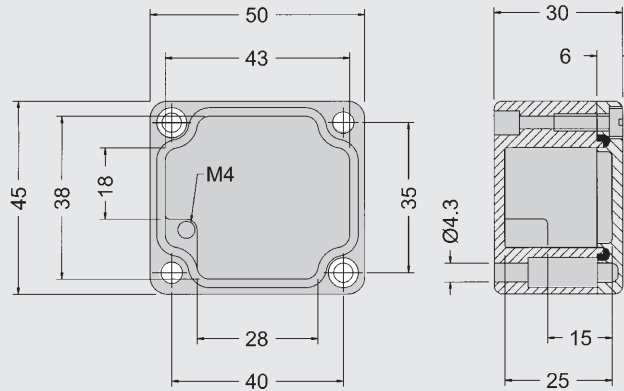

ZAG 2

Size: 64 x 58 x 36mm
Weight: 170g
Rating: 0.900Watts

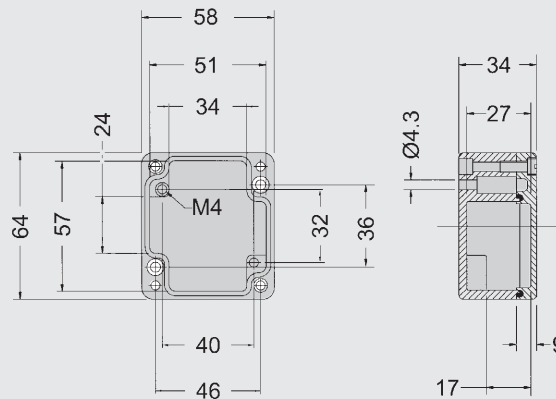

ZAG 3

Size: 98 x 64 x 36mm
Weight: 220g
Rating: 1.200Watts

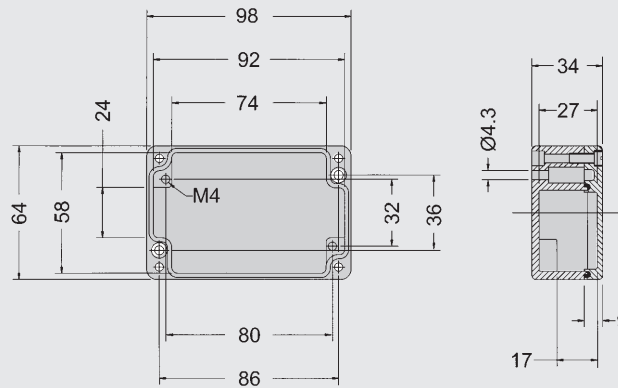

ZAG 4

Size: 150 x 64 x 36mm
Weight: 330g
Rating: 1.700Watts

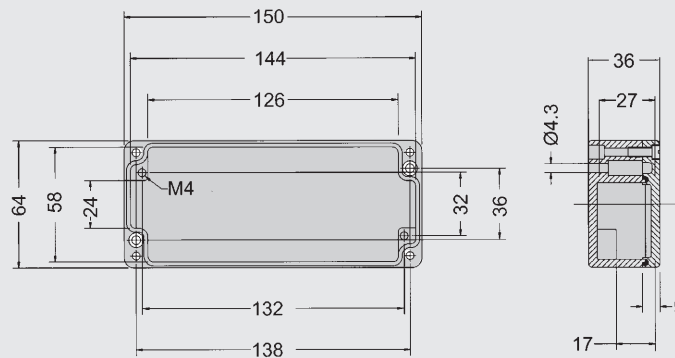

Precision die-cast aluminium enclosures offering protection to IP 67. Temp range -40°C to 80°C with standard gasket or -70°C to 130°C with silicone gasket. Standard finish in epoxy polyester paint, RAL 7001 grey. Can be painted in a variety of colours.



ABTECH ZAG RANGE

ZAG 5

Size: 75 x 80 x 57mm
 Weight: 290g
 Rating: 1.500Watts

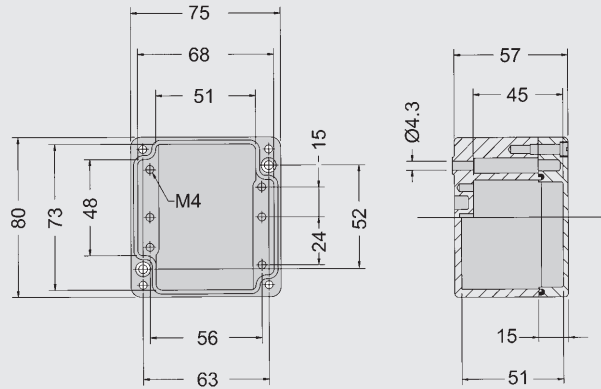

ZAG 6

Size: 125 x 80 x 57mm
 Weight: 435g
 Rating: 2.200Watts

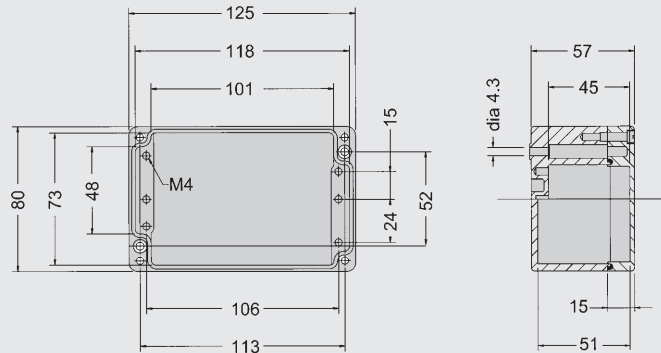

ZAG 7

Size: 175 x 80 x 57mm
 Weight: 540g
 Rating: 2.900Watts

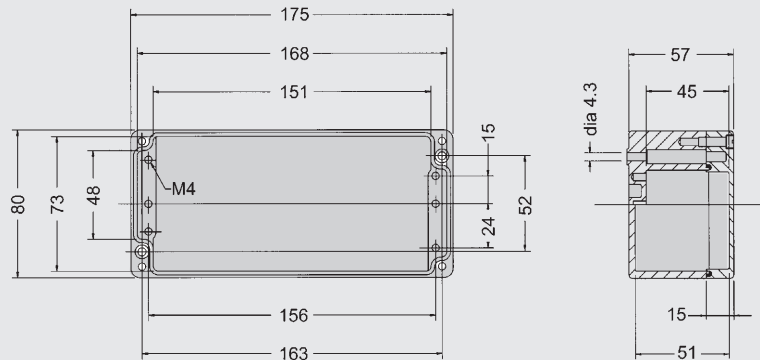

ZAG 8

Size: 250 x 80 x 54mm
 Weight: 710g
 Rating: 2.900Watts

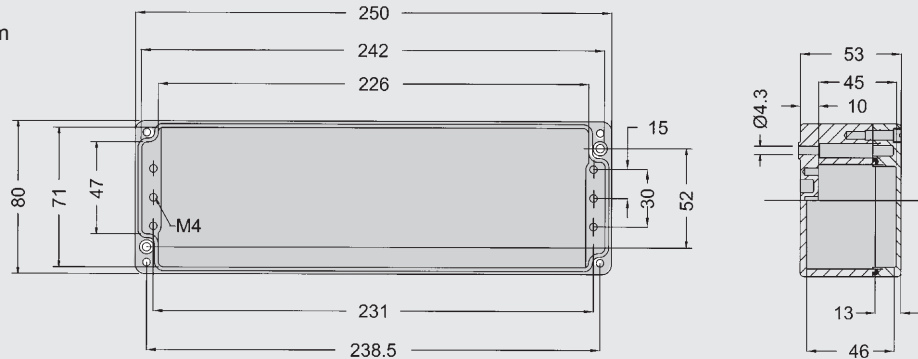

Precision die-cast aluminium enclosures offering protection to IP 67. Temp range -40°C to 80°C with standard gasket or -70°C to 130°C with silicone gasket. Standard finish in epoxy polyester paint, RAL 7001 grey. Can be painted in a variety of colours.

ABTECH ZAG RANGE

ZAG 9 & ZAG 9/9

Size: 122 x 120 x 80mm (9)
 122 x 120 x 90mm (9/9)
 Weight: 940g/965g
 Rating: 3.400Watts

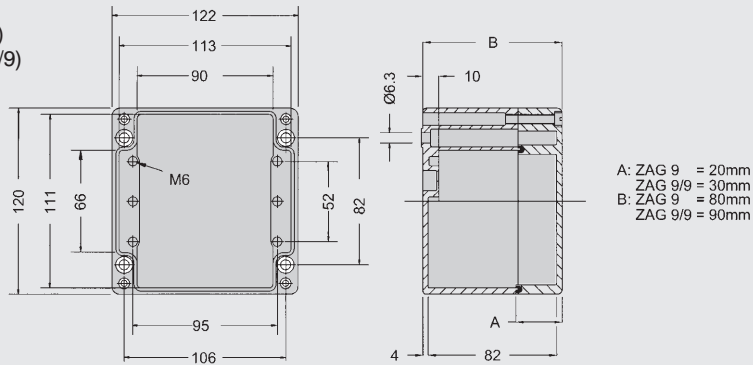

ZAG 10 & ZAG 10/9

Size: 220 x 120 x 80mm (10)
 220 x 120 x 90mm (10/9)
 Weight: 1410g/1440g
 Rating: 5.400Watts

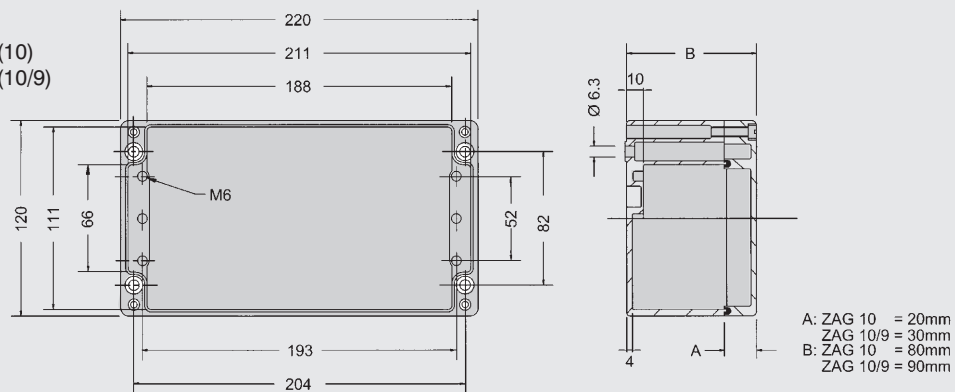

ZAG 11

Size: 160 x 160 x 90mm
 Weight: 1410g
 Rating: 5.400Watts

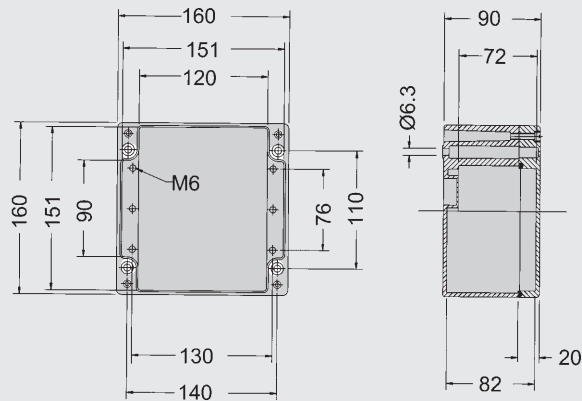

ZAG 12

Size: 260 x 160 x 90mm
 Weight: 1960g
 Rating: 8.000Watts

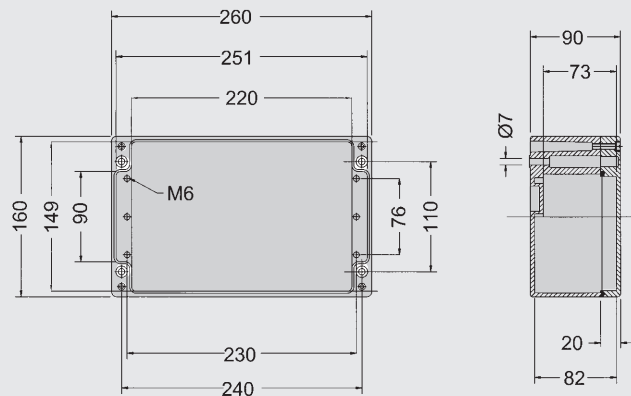

Precision die-cast aluminium enclosures offering protection to IP 67. Temp range -40°C to 80°C with standard gasket or -70°C to 130°C with silicone gasket.
 Standard finish in epoxy polyester paint, RAL 7001 grey.
 Can be painted in a variety of colours.



ABTECH ZAG RANGE

ZAG 13

Size: 360 x 160 x 90mm
 Weight: 2550g
 Rating: 10.400Watts

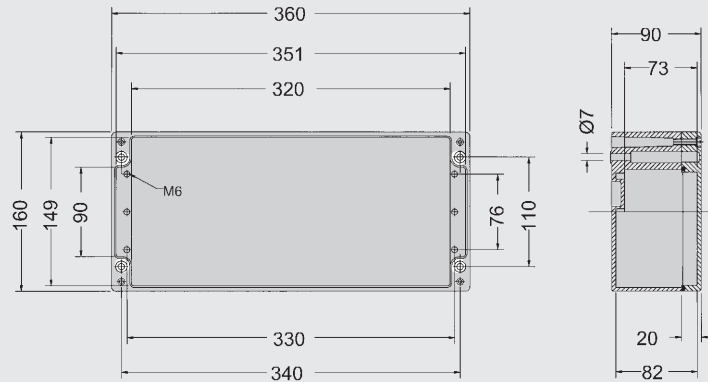

ZAG 14

Size: 560 x 160 x 90mm
 Weight: 4310g
 Rating: 10.400Watts

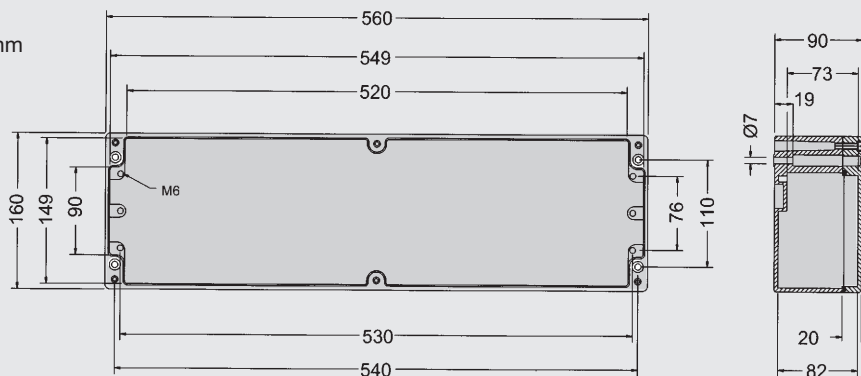

ZAG 15

Size: 200 x 230 x 110mm
 Weight: 2750g
 Rating: 9.500Watts

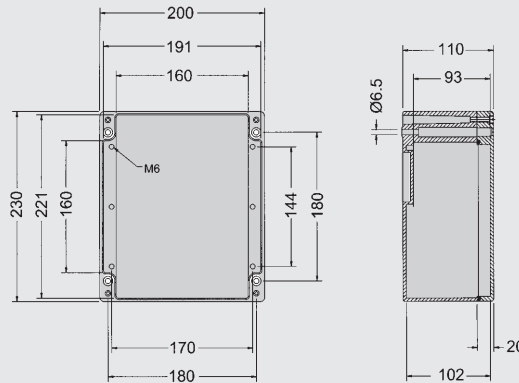

ZAG 16

Size: 330 x 230 x 110mm
 Weight: 4270g
 Rating: 14.000Watts

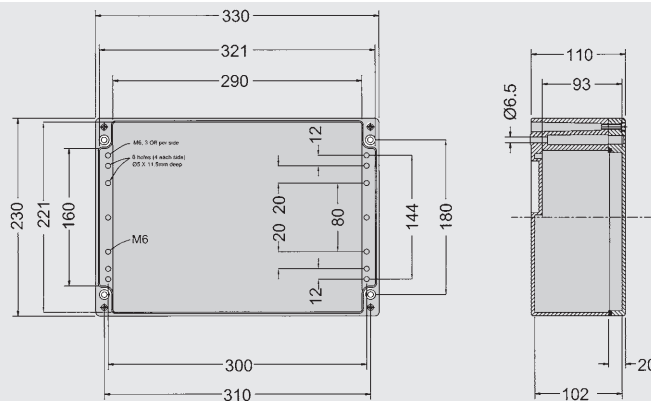

Precision die-cast aluminium enclosures offering protection to IP 67. Temp range -40°C to 80°C with standard gasket or -70°C to 130°C with silicone gasket. Standard finish in epoxy polyester paint, RAL 7001 grey. Can be painted in a variety of colours.

ABTECH ZP RANGE

The Abtech ZP range of enclosures comprises 19 sizes which are injection moulded in either ABS plastic or polycarbonate material with the option of a clear polycarbonate lid which can be fitted to either base.

The enclosure are lightweight yet extremely robust and offer good protection against both corrosion and oil based contamination. The enclosure shares the labyrinth seal arrangement which is common to both the ZAG and BPG ranges and can offer protection up to IP65. Stainless steel captive quick release quarter turn screws are fitted as standard offering a quick and reliable method of securing the lid. This can provide a considerable cost saving in assembly times with on-average savings of 2 minutes per enclosure over conventional screws. As an option conventional screws may be fitted if required.

The mounting holes, although contained within the profile of the enclosure, sit outside the seal and all external fasteners and fixings are manufactured from 316 grade stainless steel to ensure reliability. External stainless steel mounting feet are offered as an option.

The ZP range is an extremely versatile enclosure with many uses including junction boxes, instrument enclosures and of course suitable for many OEM applications. The addition of the clear lid makes the ZP range particularly suitable for housing instruments and indicators where a visual indication is

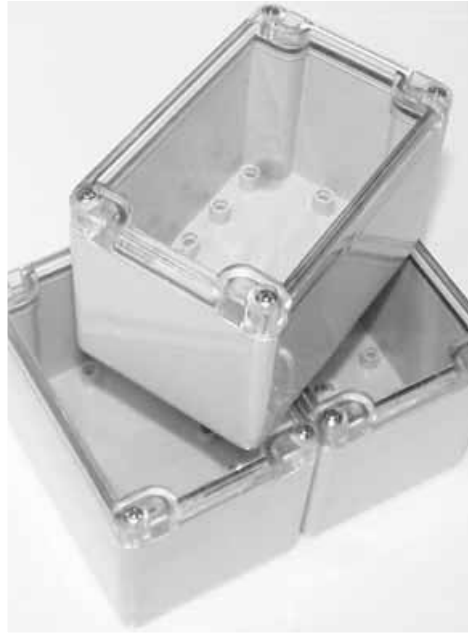

required without the need for opening the enclosure.

The ZP range can be machined, drilled and tapped with various thread forms and can also be silk screen printed. The ZP range can be moulded in almost any colour subject to minimum quantities.

At our factories in England, Germany and the United States we have recently introduced specialist machining centres for the ZP range. These new machines allow dedicated tooling and programming specific to the requirements of the materials used and reflect the increasing useage of this enclosure range especially in small batch production.

Internal components are located via a series of moulded pillars which can be fitted with threaded inserts or alternatively can accept self tapping screws and these are used for the fitment of a component mounting plate or DIN standard terminal mounting rails such as TS-15, TS-32 or TS-35.

Earthing can be accomplished by various means. External/internal earth stud which in turn can be connected to the terminal mounting rail or component mounting plate and various rail mounted earth terminals or proprietary earth bars can be fitted inside the enclosure.

When fitted with a standard neoprene gasket the enclosure is suitable for ambient temperatures of -40°C to 80°C. Alternatively when fitted with an optional silicone gasket the temperature range is increased to -70°C to 130°C.

RFI screening is achieved by the use of a metalised coating of 50 micron thickness to the internal surfaces of the enclosure and the fitment of an RFI gasket. The Abtech sales team can give advice on suitable RFI gaskets and finishing techniques which will provide optimum protection but typically the following characteristics are achievable:

Attenuation

55-65 dB @ 500 to 1000MHz
35 dB @ 40k to 300MHz



ABTECH ZP RANGE

ACCESSORIES

The following table is a list of the available accessories suitable for particular sizes of ZP enclosures.

Size	Dimensions	M	E	F	H	RFI	T	SIL	SF	T
ZP 1	52 x 50 x 35	n	-	n	-	n	n	n	-	-
ZP 2	65 x 50 x 35	n	-	n	-	n	n	n	n	n
ZP 3	82 x 80 x 55	n	n	n	n	n	n	n	n	n
ZP 4	82 x 80 x 85	n	n	n	n	n	n	n	n	n
ZP 5	120 x 80 x 55	n	n	n	n	n	n	n	n	n
ZP 6	120 x 80 x 85	n	n	n	n	n	n	n	n	n
ZP 7	160 x 80 x 55	n	n	n	n	n	n	n	n	n
ZP 8	160 x 80 x 85	n	n	n	n	n	n	n	n	n
ZP 9	122 x 120 x 55	n	n	n	n	n	n	n	n	n
ZP 10	122 x 120 x 85	n	n	n	n	n	n	n	n	n
ZP 11	200 x 120 x 75	n	n	n	n	n	n	n	n	n
ZP 12	200 x 150 x 75	n	n	n	n	n	n	n	n	n
ZP 13	240 x 120 x 100	n	n	n	n	n	n	n	n	n
ZP 14	240 x 160 x 90	n	n	n	n	n	n	n	n	n
ZP 15	250 x 160 x 90	n	n	n	n	n	n	n	n	n
ZP 16	240 x 160 x 120	n	n	n	n	n	n	n	n	n
ZP 17	300 x 230 x 85	n	n	n	n	n	n	n	n	n
ZP 18	360 x 200 x 150	n	n	n	n	n	n	n	n	n
ZP 19	300 x 230 x 110	n	n	n	n	n	n	n	n	n

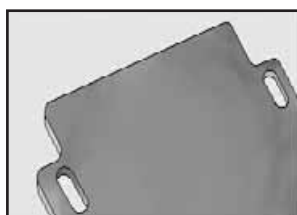

M
Component mounting plate
(Tufnol - standard, steel - option)

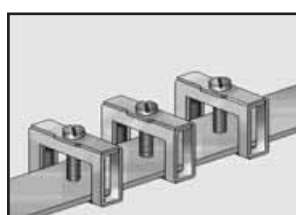

E
Internal earthing bar
(can be fitted with clamps)

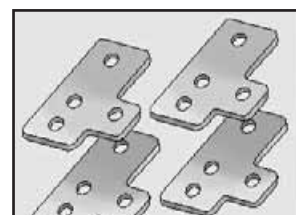

F
External mounting feet
(stainless steel grade 316)

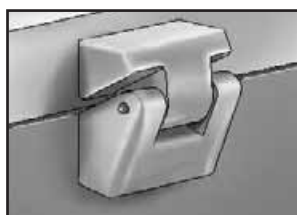

H
External Hinges

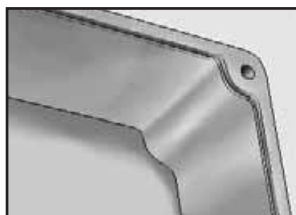

RFI
Metalised spray coating to interior of enclosure for RFI shielding



T
Transparent lid in polycarbonate

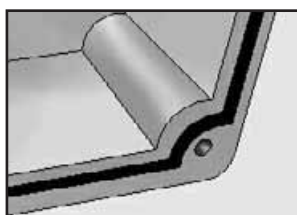

SIL
Silicone lid gasket



SF
Standard screw fastener

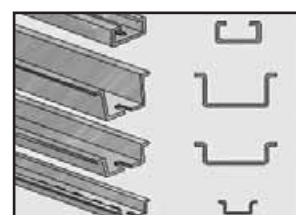

T
DIN standard mounting rail
(TS 15, TS 32 or TS 35 please specify)

ABTECH ZP RANGE

TERMINAL CONTENTS

The following table is provided as a guide only. Due to space limitations in this brochure only Weidmuller and Phoenix terminal populations are shown. Any terminal type or component may be fitted and a number of mounting options such as component mounting plates and terminal rails are available for use with the ZP range of enclosures. Abtech sales staff will be pleased to advise on the use and fitment of any components.

WEIDMULLER													PHOENIX												
SIZE	Solid mm ²	4	4	4	6	6	4	6	10	16	16	50	4	4	4	4	4	4	4	10	10	16	16	35	
	Stranded mm ²	4	6	10	16	16	35	4	6	10	16	35	4	4	4	2.5	2.5	4	4	6	6	10	10	35	
CURRENT(A)		21	21	21	26	26	21	28	36	50	66		21	21	21	21	21	21	21	37	37	47	47	75	
TERMINAL TYPE	NO. OF ROWS	BK 4 (4 way)	BK 6 (6 way)	BK 12 (12 way)	MK 6/4	MK 6/6	SAK 2.5	SAK 4	SAK 6N	SAK 10	SAK 16	SAK 35	GS/4 (4 way)	GS/6 (6 way)	GS/12 (12 way)	K 3	UK 3	K 5	UK 5	K 10	UK 10	K 16	UK 16	UK 35	
BOX TYPE																									
ZP 1 1	1	1	-	1	-	-	-	-	-	-	-	1	1	-	-	-	-	-	-	-	-	-	-	-	
ZP 2 1	2	1	-	1	1	-	-	-	-	-	-	2	1	-	-	-	-	-	-	-	-	-	-	-	
ZP 3 1	3	-	1	2	1	-	-	-	-	-	-	3	2	1	-	-	-	-	-	-	-	-	-	-	
ZP 4 1	4	-	1	3	2	-	-	-	-	-	-	4	3	1	-	-	-	-	-	-	-	-	-	-	
ZP 5 1	5	3	2	4	2	-	-	-	-	-	-	5	3	2	-	-	-	-	-	-	-	-	-	-	
ZP 6 1	-	-	-	-	-	10	9	7	6	5	3	-	-	-	12	12	10	10	6	6	6	6	4	-	
ZP 7 1	-	-	-	-	-	26	24	20	16	13	10	-	-	-	30	30	25	25	19	19	15	15	10	-	
ZP 8 1	-	-	-	-	-	16	15	12	9	8	5	-	-	-	19	19	16	16	12	12	9	9	5	-	
ZP 9 1	-	-	-	-	-	33	30	25	20	16	12	-	-	-	38	38	32	32	24	24	19	19	13	-	
ZP 10	1	-	-	-	-	-	48	45	36	29	24	18	-	-	-	56	56	48	48	36	36	29	29	18	
ZP 11	1	-	-	-	-	-	80	74	61	48	41	30	-	-	-	94	94	78	78	58	58	46	46	32	
ZP 12	1	-	-	-	-	-	31	29	24	19	16	12	-	-	-	37	37	31	31	23	23	18	18	12	
ZP 13	1	-	-	-	-	-	62	58	48	38	-	-	-	-	-	74	74	62	62	46	46	36	36	-	
ZP 14	1	-	-	-	-	-	55	50	41	33	27	20	-	-	-	64	64	53	53	40	40	32	32	22	
ZP 15	1	-	-	-	-	-	110	100	82	66	-	-	-	-	-	128	128	106	106	80	80	64	64	-	
ZP 16	1	-	-	-	-	-	87	81	66	52	41	32	-	-	-	103	103	86	86	64	64	51	51	34	
ZP 17	1	-	-	-	-	-	174	162	132	104	82	64	-	-	-	206	206	172	172	128	128	102	102	-	
ZP 17	2	-	-	-	-	-	55	50	41	33	27	20	-	-	-	64	64	53	53	40	40	32	32	22	
ZP 18	1	-	-	-	-	-	110	100	82	66	54	-	-	-	-	128	128	106	106	80	80	64	64	-	
ZP 18	2	-	-	-	-	-	174	162	132	104	82	64	-	-	-	206	206	172	172	128	128	102	102	-	
ZP 19	1	-	-	-	-	-	55	50	41	33	27	20	-	-	-	64	64	53	53	40	40	32	32	22	
ZP 19	2	-	-	-	-	-	110	100	82	66	54	-	-	-	-	128	128	106	106	80	80	64	64	-	
ZP 18	1	-	-	-	-	-	110	100	82	66	54	-	-	-	-	128	128	106	106	80	80	64	64	-	
ZP 18	2	-	-	-	-	-	174	162	132	104	82	64	-	-	-	206	206	172	172	128	128	102	102	-	
ZP 19	1	-	-	-	-	-	55	50	41	33	27	20	-	-	-	64	64	53	53	40	40	32	32	22	
ZP 19	2	-	-	-	-	-	110	100	82	66	54	-	-	-	-	128	128	106	106	80	80	64	64	-	

The above power ratings apply to an ambient operating temperature of 40°C.

ABTECH ZP RANGE

ZP 1

Size: 52 x 50 x 35mm
 Weight: PC 40g
 ABS 38g

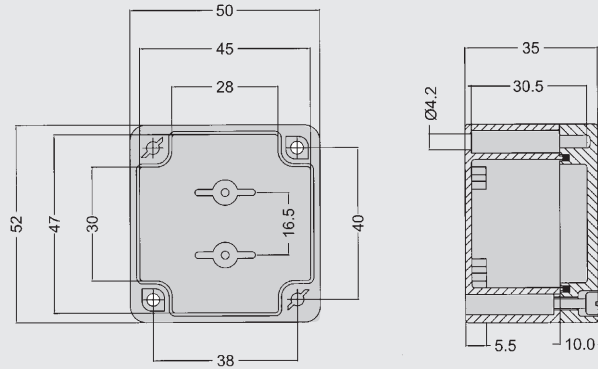

ZP 2

Size: 65 x 50 x 35mm
 Weight: PC 50g
 ABS 48g

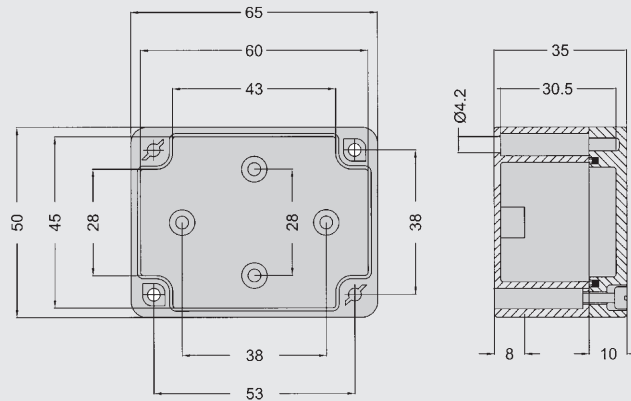

ZP 3

Size: 82 x 80 x 55mm
 Weight: PC 150g
 ABS 145g

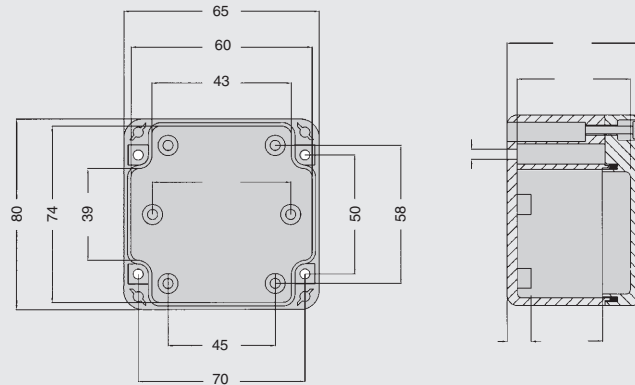

ZP 4

Size: 82 x 80 x 85mm
 Weight: PC 175g
 ABS 156g

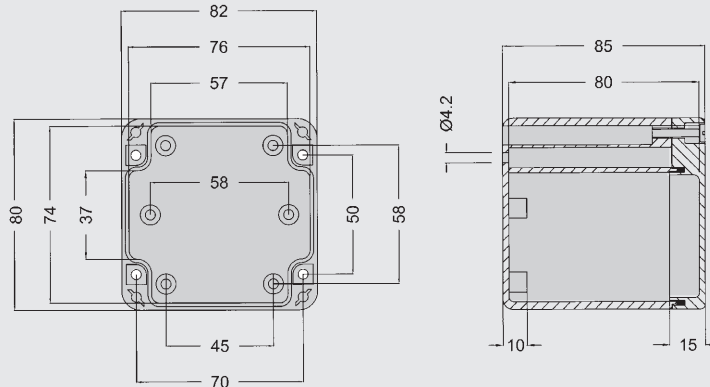

Polycarbonate/ABS enclosures offering protection to IP 65.
 Temp range -40°C to 80°C with standard gasket or -40°C to 120°C with silicone gasket.
 Standard finish as moulded is RAL 7035 grey.
 Can be moulded in variety of colours.

ABTECH ZP RANGE

ZP 5

Size: 120 x 80 55mm
 Weight: PC 180g
 ABS 175g

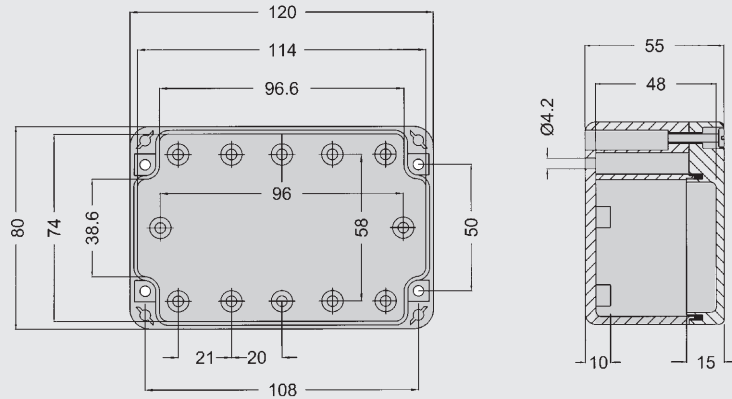

ZP 6

Size: 120 x 80 85mm
 Weight: PC 225g
 ABS 205g

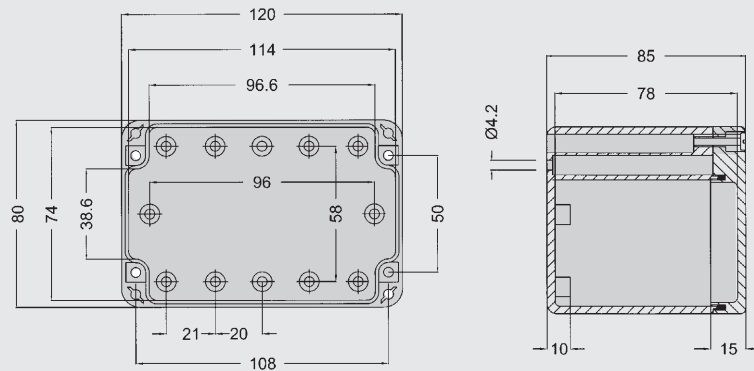

ZP 7

Size: 160 x 80 x 55mm
 Weight: PC 225g
 ABS 205g

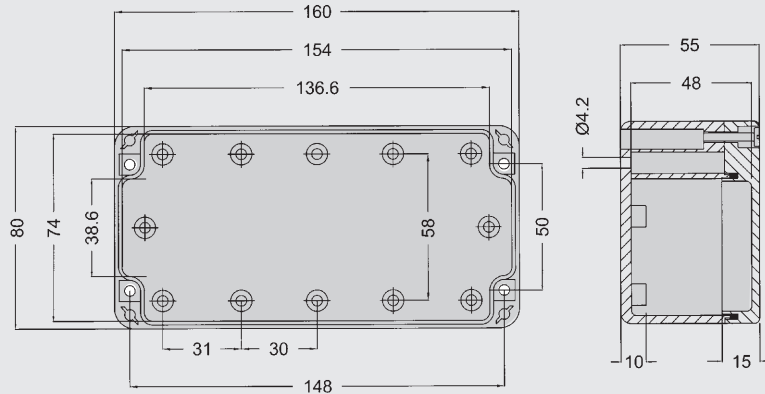

ZP 8

Size: 160 x 80 x 85mm
 Weight: PC 250g
 ABS 235g

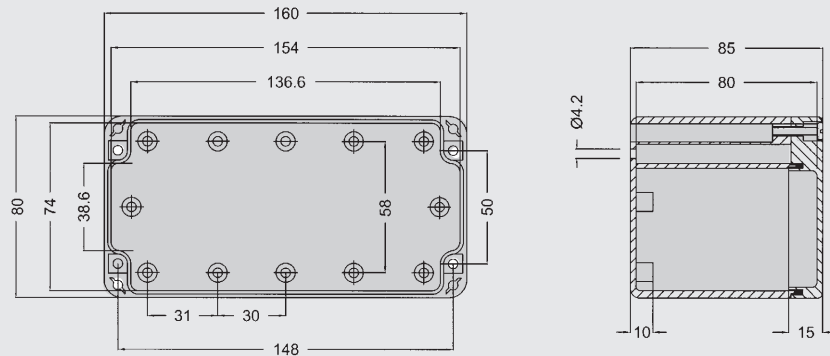

Polycarbonate/ABS enclosures offering protection to IP 65.
 Temp range -40°C to 80°C with standard gasket or -40°C to 120°C with silicone gasket.
 Standard finish as moulded is RAL 7035 grey.
 Can be moulded in variety of colours.



ABTECH ZP RANGE

ZP 9

Size: 122 x 120 x 55mm
 Weight: PC 240g
 ABS 220g

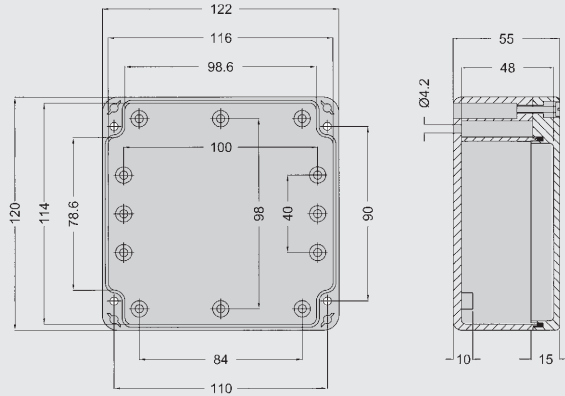

ZP 10

Size: 122 x 120 x 85mm
 Weight: PC 295g
 ABS 270g

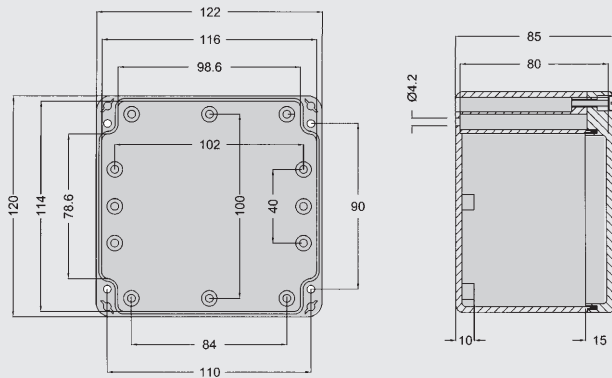

ZP 11

Size: 200 x 120 x 75mm
 Weight: PC 400g
 ABS 380g

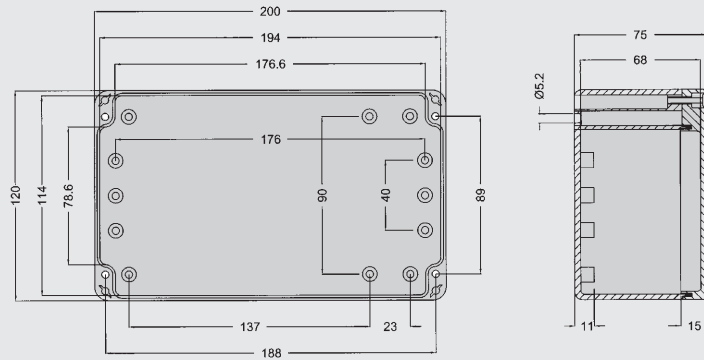

ZP 12

Size: 200 x 150 x 75mm
 Weight: PC 475g
 ABS 440g

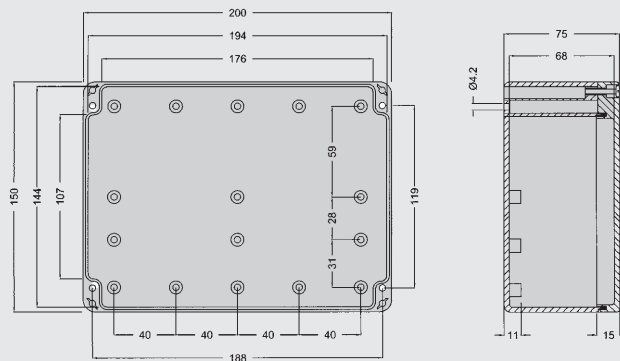

Polycarbonate/ABS enclosures offering protection to IP 65.
 Temp range -40°C to 80°C with standard gasket or -40°C to 120°C with silicone gasket.
 Standard finish as moulded is RAL 7035 grey.
 Can be moulded in variety of colours.



ABTECH ZP RANGE

ZP 13

Size: 240 x 120 x 100mm
 Weight: PC 550g
 ABS 495g

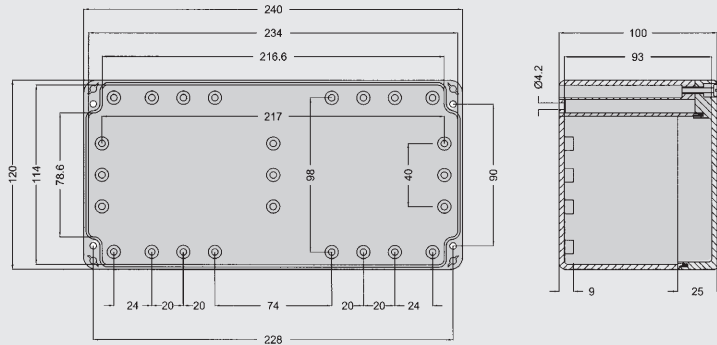

ZP 14

Size: 240 x 160 x 90mm
 Weight: PC 645g
 ABS 575g

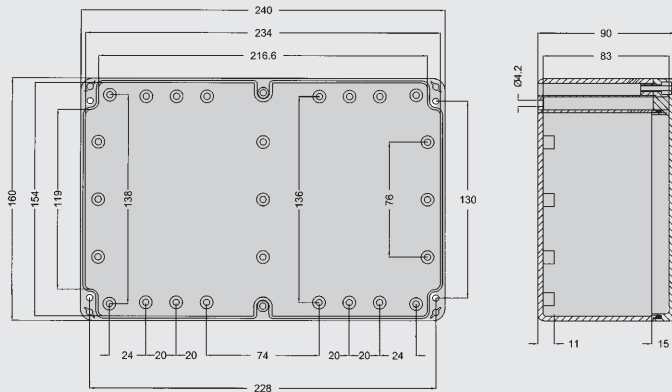

ZP 15

Size: 250 x 160 x 90mm
 Weight: PC 655g
 ABS 585g

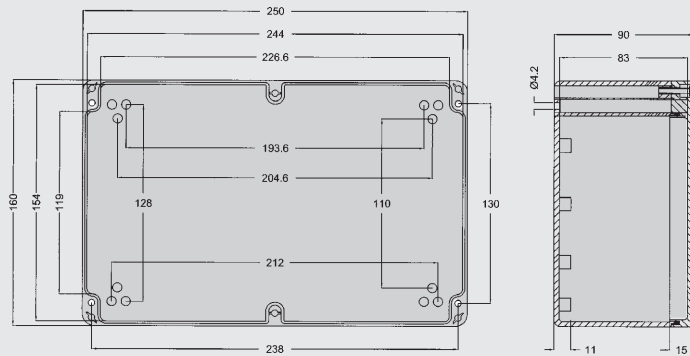

ZP 16

Size: 240 x 160 x 120mm
 Weight: PC 805g
 ABS 720g

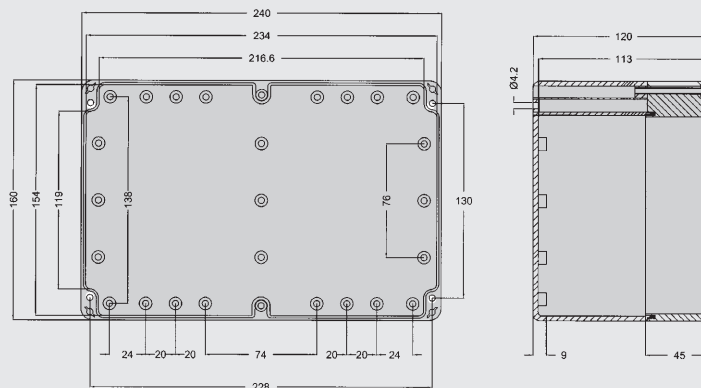

Polycarbonate/ABS enclosures offering protection to IP 65.
 Temp range -40°C to 80°C with standard gasket or -40°C to 120°C with silicone gasket.
 Standard finish as moulded is RAL 7035 grey.
 Can be moulded in variety of colours.



ABTECH ZP RANGE

ZP 17

Size: 300 x 230 x 85mm

Weight: PC 930g

ABS 875g

Rating: x.xxxWatts

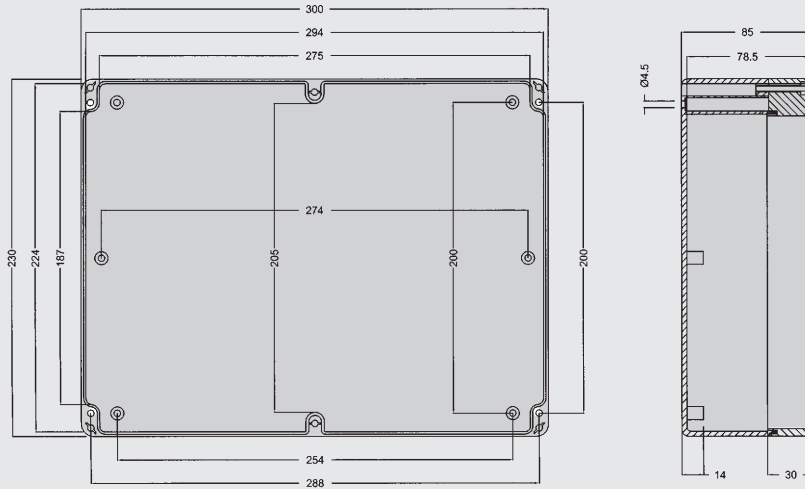

ZP 18

Size: 360 x 200 x 150mm

Weight: PC 1850g

ABS 1625g

Rating: x.xxxWatts

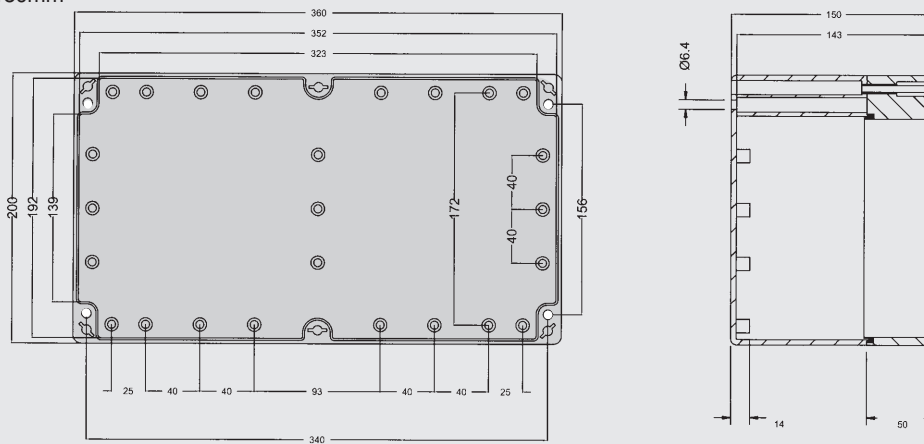

ZP 19

Size: 300 x 230 x 110mm

Weight: PC 1250g

ABS 1025g

Rating: x.xxxWatts

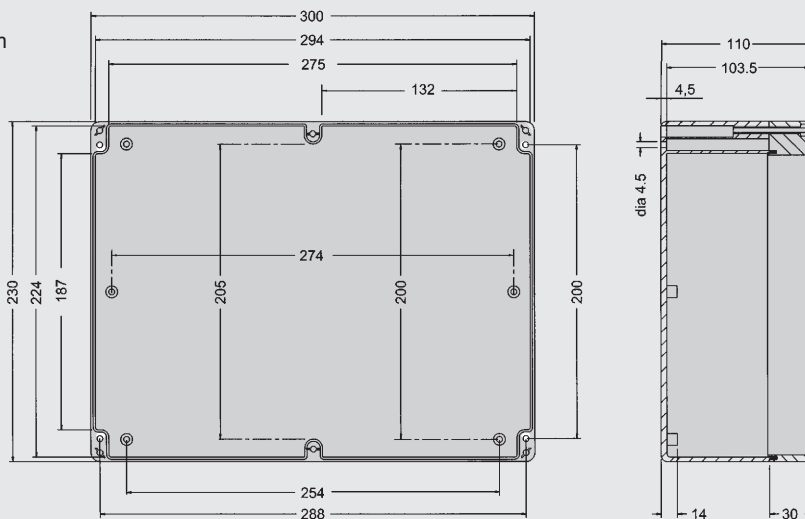

Polycarbonate/ABS enclosures offering protection to IP 65. Temp range -40°C to 80°C with standard gasket or -40°C to 120°C with silicone gasket. Standard finish as moulded is RAL 7035 grey. Can be moulded in variety of colours.

ABTECH GPS RANGE

The Abtech GPS range comprises 26 different sized mild steel enclosures. They are manufactured in mild steel and painted in high quality epoxy polyurethane powder-coat paint, beige RAL 7032, for a long lasting and durable finish.

The cabinets are fitted with either one or two hinged doors as standard and a cylinder lock with special key.

The range comes complete with wall mounting brackets as standard and a bottom gland plate for cable entries.

Ingress protection is IP65 to EN 60529.

Custom sizes are available to special order.

Contact Abtech sales staff with your requirements.



Options include:

- Internal component mounting plate in 2mm thick galvanised mild steel
- Key lock
- Rain Hood

Reference Number	W (mm)	H (mm)	D (mm)	Weight (kg)	Mounting Plate	Weight (kg)	DOOR No.	Gland Plate	Lock No.
GPS2315	200	300	150	3.5	MP23	0.7	1	1	1
GPS3315	300	300	150	4.9	MP33	1.0	1	1	1
GPS3320		300	200	5.6	MP33	1.0	1	1	1
GPS3415		400	150	6.0	MP34	1.4	1	1	1
GPS3420		400	200	7.0	MP34	1.4	1	1	1
GPS3520		500	200	8.3	MP35	1.8	1	1	1
GPS4315	400	300	150	6.0	MP43	1.4	1	1	1
GPS4420		400	200	8.2	MP44	1.9	1	1	1
GPS4520		500	200	10.2	MP45	2.5	1	1	1
GPS40620		600	200	11.7	MP46	3.1	1	1	2
GPS4630		600	300	14.3	MP46	3.1	1	1	2
GPS5520	500	500	200	12.0	MP55	3.1	1	1	1
GPS5720		700	200	15.3	MP57	4.6	1	1	2
GPS5730		700	300	18.4	MP57	4.6	1	1	2
GPS6420	600	400	200	13.1	MP64	3.0	1	1	1
GPS6620		600	200	15.9	MP66	4.7	1	1	2
GPS6630		600	300	19.1	MP66	4.7	1	1	2
GPS6820		800	200	19.4	MP68	6.6	1	1	2
GPS6830		800	300	23.0	MP68	6.6	1	1	2
GPS61020		1000	200	22.8	MP610	8.3	1	1	2
GPS61030		1000	300	26.8	MP610	8.3	1	1	2
GPS61230		1160	300	33.7	MP612	9.7	1	1	2
GPS8620	800	600	200	20.4	MP86	6.4	2	2	1*
GPS81030		1000	300	34.3	MP810	11.3	2	2	1*
GPS10630	1000	600	300	29.3	MP106	8.2	2	2	1*
GPS101030	1000	1000	300	43.4	MP1010	14.4	2	2	1*

* denotes rod - latch type mechanism

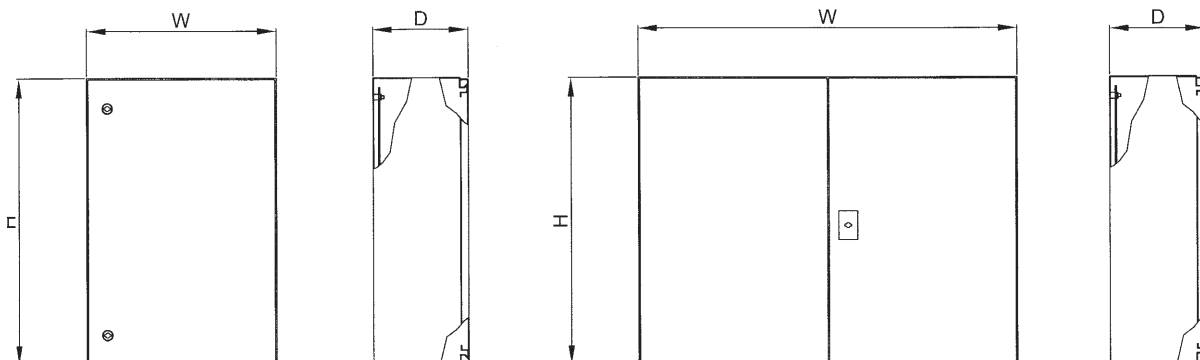

HIGH VOLTAGE RANGE

For many years, Abtech have been at the forefront in the design and manufacture of high voltage connection solutions for use in hazardous areas. Through constantly listening to customer needs, the range has been developed and expanded to five types as shown in the table below and with the many variations possible within the five ranges there are more than 50 combinations to choose from.

MJB Range: The MJB range provides a simple, low cost & effective solution for the connection of cables. Used primarily for joining cables or as a connection box. Max voltage 8.3kV.



MJB

DPJB Range: The original high voltage down hole pump connection box which has been used by many customers all over the world. Can be used as a connection box or a splitter box with up to four ways possible. Max voltage 11kV and fault tested to 50kA for 1 second.



DPJB

HVJB Range: The latest in the High Voltage range offering enhanced flexibility over the choice of cables, entries and cable terminations. Max. voltage 11kV.



HVJB

LR Range: A specialist application originally designed for a specific customer, but has increasingly been used by many more customers with a need for the flexible arrangement this enclosure provides. Max voltage 11kV.



LRJB

Busbar Box: A busbar box with a maximum voltage of 11kV, a current capacity of 3000 A per phase and a fault rating of 80kA for 1 second. Capable of connecting 3 phase & neutral and up to 6 cables per phase.



BUSBAR

All Abtech high voltage enclosures are manufactured in 316 grade stainless steel and have an IP rating of IP66 as standard with IP67 available.

All enclosure are ATEX certified by SIRA for use in a Category 2/Zone 1 area and Category 3/Zone 2 area.

The entire range offers flexibility in terms of both connection options and mounting arrangements.

New variations are continually being added to the High Voltage range.

Whatever your requirement may be for high voltage connections in hazardous areas call Abtech for the solution.



Enclosure Type	Max. Current (A) or Power rating (W)	Max. Voltage (kV)	Max. Ways	Max. split per way	Size
MJB Range	50	8.3	4	1	SX5 to SX8
DPJB Range	48.6	11kV	4	4	SX5 to SX8
HVJB Range	1250A	11kV	4	4	SX5 to SX8
LR Connection Box	1250A	3.3kV	3	2	SX5 to SX8
Busbar Box	3000A	11kV	4	6	770 x 770 x 1250mm (max)

ABTECH MJB RANGE

The Abtech MJB range offers a simple and effective means of connecting cables or equipment, and is suitable for voltages up to a maximum of 8.3kV.

The MJB range is manufactured in either mild steel or stainless steel and utilises the SX range of enclosures from SX 5 through to SX 8 all available in either 200 or 300mm depths. These are the standard sizes depending on maximum operating voltage and conductor sizes, although custom sizes can be manufactured to special order.

By using the SX design the same benefits are afforded to the MJB range. These benefits include: ingress protection to IP66 as standard with IP67 available as an option, enclosure tested to the Shell/ERA deluge specification, heavy duty construction, padlock facility and internal/external earth stud fitted as standard.

All hazardous area versions are ATEX certified using the latest standards and are suitable for operation in a Category 2/Zone 1 area and Category 3/Zone 2 area.

Standard operating ambient temperature is in the range -20°C to +40°C. Versions are available which can accommodate an ambient temperature range of -50°C to +65°C.

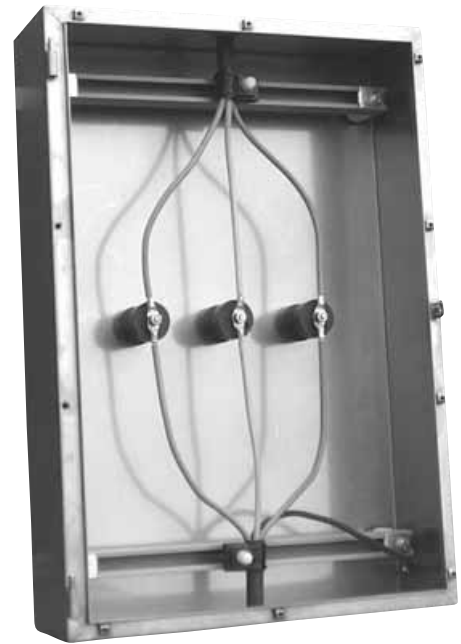

Enclosure Type	Maximum Power rating (W)	Max. Voltage (kV)	Max. Ways	Maximum Conductor(mm-)	Size (mm)
MJB 5	16	6.6	3	120	510 x 510 x 200/300
MJB 5	16	8.3	3	35	510 x 510 x 300
MJB 6	23	6.6	3	120	510 x 780 x 200/300
MJB 6	23	8.3	3	35	510 x 780 x 300
MJB 7	33	6.6	4	240	650 x 950 x 200/300
MJB 7	33	8.3	4	240	650 x 950 x 200
MJB 8	50	6.6	4	240	800 x 1250 x 200/300
MJB 8	50	8.3	4	240	800 x 1250 x 300



	Dim A	Dim B	Dim C	Dim D
MJB 5	510	510	560	360
MJB 6	780	510	560	580
MJB 7	950	650	700	750
MJB 8	1250	800	850	1050

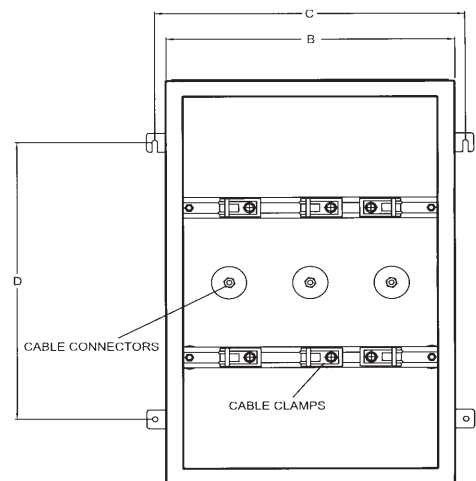
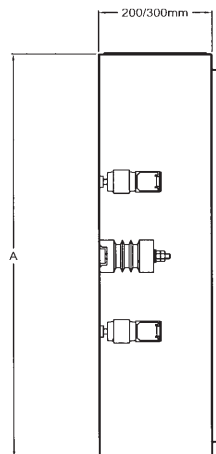

ABTECH DPJB RANGE

The Abtech DPJB range offers an effective means of connecting cables or equipment up to a maximum of 11kV and is fault rated to 50kA for 1 second. Cable conductor sizes of up to 630mm can be accommodated depending on the size of enclosure and number of conductors. The DPJB range is manufactured in either mild steel or stainless steel and utilises the SX 7 and SX8 enclosures in either 200 or 300mm depth depending on the operating voltage.

By using the SX range design the same benefits are afforded to the DPJB range. These benefits include: ingress protection to IP66 as standard with IP67 available as an option, enclosure tested to the Shell/ERA deluge specification, heavy duty construction, padlock facility and internal/external earth stud fitted as standard.

All hazardous area versions are ATEX certified using the latest standards and are suitable for operation in a Category 2/Zone 1 area and Category 3/Zone 2 area.

Standard operating ambient temperature is in the range -20°C to +40°C. Versions are available which can accommodate an ambient temperature range of -50°C to +65°C (special order only).

A double compartment version is available with a separate compartment which can be used to terminate control cables or fibre optic cables. This allows access to the low voltage/ fibre compartment without having to de-energise the high voltage compartment. Versions are also available with Purge protection for use in Class 1 /Division 2 areas.

Phase segregation barriers are fitted as standard.

The DPJB range can be used as either a through box or with both the incoming and outgoing cable entering via the one end. In the latter instance it is important to consider the bending radii of the cables to ensure the enclosure is large enough.

Spare copper crimp lugs are available from Abtech to allow repairs or re-use of the enclosure.



Enclosure Type	Maximum Power rating (W)	Max. Voltage (kV)	Max. Ways	Maximum Conductor(mm=)	Size (mm)
DPJB 1	48.6	6.6	3*	630	650 x 950 x 200
DPJB 3	48.6	6.6	4*	630	650 x 950 x 200
DPJB 5	48.6	6.6	3*	630	800 x 1250 x 300
DPJB 7	48.6	6.6	4*	630	800 x 1250 x 300
DPJB 9	48.6	11	3*	630	800 x 1250 x 300
DPJB 11	48.6	11	4*	630	800 x 1250 x 300
DPJB 2**	50	6.6	4	95	650 x 950 x 200 min.

Note:

Each way can be fitted with a 2 or 3 way splitter bar.

The DPJB range utilises special copper crimp lugs for the connection of the conductors, with the exception of the DPJB 2 type which utilises elastimold couplers.

ABTECH DPJB RANGE

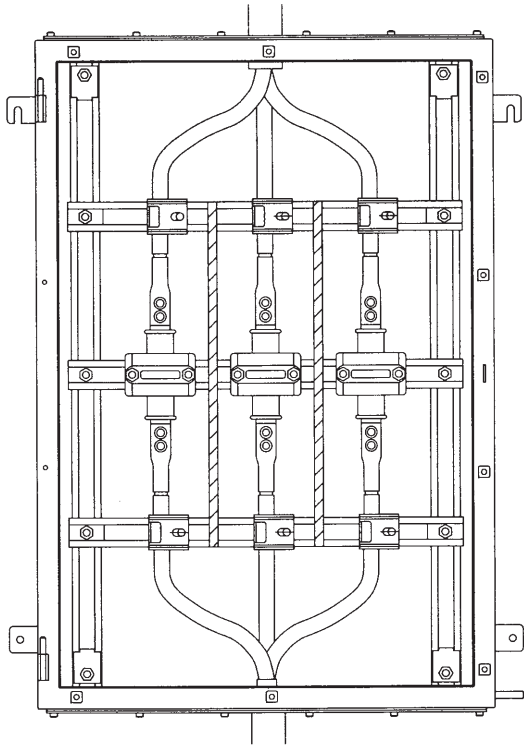

A typical DPJB 1 showing 3 cable couplers with phase separators and top and bottom gland plates.

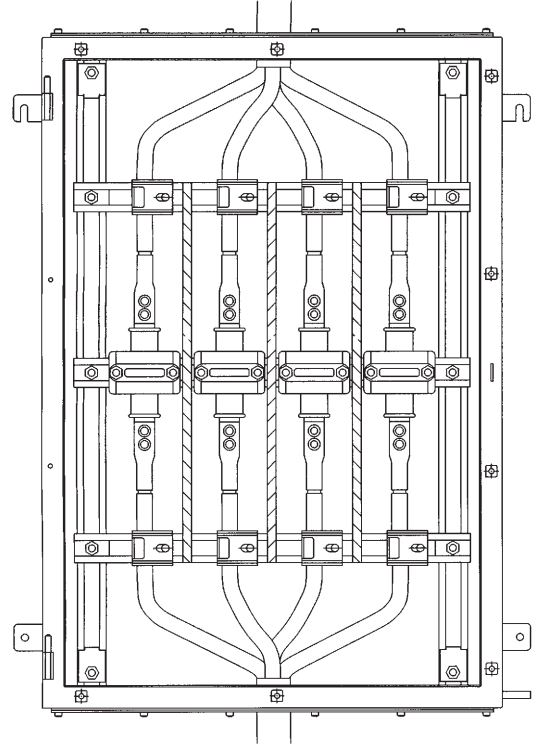

A typical DPJB 3 showing 4 cable couplers with phase separators and top and bottom gland plates.

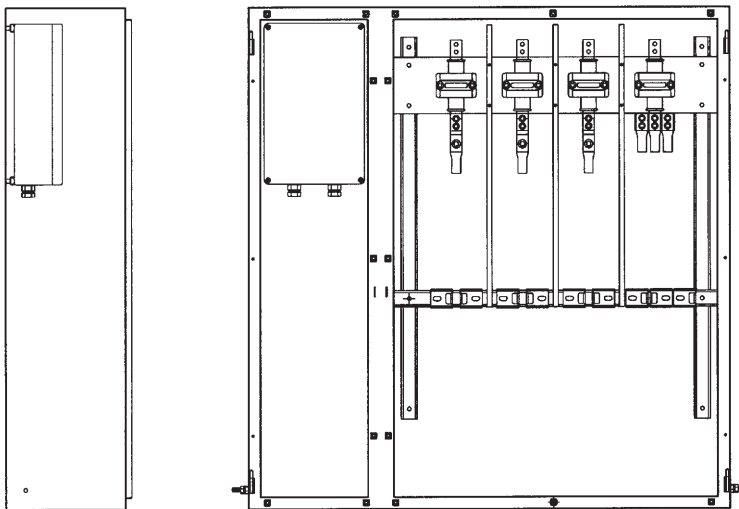

An example of a double compartment DPJB 11. A BPG 13 is located in the smaller compartment for the termination of fibre optic cables. The HV couplers are placed at the top of the compartment to allow more room for cabling as all cables enter and leave through the bottom of the enclosure.



ABTECH HVJB RANGE

The Abtech HVJB range is the newest range in the High Voltage series and offers improved flexibility over the DPJB range in many situations and is suitable for operating voltages of up to 11kV maximum.

In conjunction with most of the High Voltage series it is manufactured in either mild steel or stainless steel and utilises the SX7 and SX8 range of enclosure. This is the standard sizes although custom sizes are available to special order.

The HVJB range can accommodate conductors up to 630mm and can split up to four phases, 3 ways in each direction. Incoming and outgoing cables can enter from the same end of the enclosure or from different ends.

By using the SX range design the same benefits are afforded to the HVJB range. These benefits include: ingress protection to IP66 as standard (IP67 available optional), enclosure tested to the Shell/ERA deluge specification, heavy duty construction, padlock facility fitted as standard and internal/external earth stud fitted as standard.

All hazardous area versions are ATEX certified to the latest standards and are suitable for operation in a Category 2/Zone 1 area and Category 3/Zone 2 area.

Standard operating ambient temperature is in the range -20°C to +40°C.

Versions are available which can accommodate an ambient temperature range of -50°C to +65°C (special order only).



Enclosure Type	Maximum Current (A)	Max. Voltage (kV)	Number Ways	Top Cables	Bottom Cables	Maximum Conductor (mm)
HVJB X3(0-2)	980	11	3	0	2	630
HVJB X3(0-3)	980	11	3	0	3	630
HVJB X3(2-0)	980	11	3	2	0	630
HVJB X3(3-0)	980	11	3	3	0	630
HVJB X3(1-1)	980	11	3	1	1	630
HVJB X3(1-2)	980	11	3	1	2	630
HVJB X3(2-1)	980	11	3	2	1	630
HVJB X3(2-2)	980	11	3	2	2	630
HVJB X3(1-3)	980	11	3	1	3	630
HVJB X3(3-1)	980	11	3	3	1	630
HVJB X3(2-3)	980	11	3	2	3	630
HVJB X3(3-2)	980	11	3	3	2	630
HVJB X3(3-3)	980	11	3	3	3	630
HVJB X4(0-2)	980	11	4	0	2	630
HVJB X4(0-3)	980	11	4	0	3	630
HVJB X4(2-0)	980	11	4	2	0	630
HVJB X4(3-0)	980	11	4	3	0	630
HVJB X4(1-1)	980	11	4	1	1	630
HVJB X4(1-2)	980	11	4	1	2	630
HVJB X4(2-1)	980	11	4	2	1	630
HVJB X4(2-2)	980	11	4	2	2	630
HVJB X4(1-3)	980	11	4	1	3	630
HVJB X4(3-1)	980	11	4	3	1	630
HVJB X4(2-3)	980	11	4	2	3	630
HVJB X4(3-2)	980	11	4	3	2	630
HVJB X4(3-3)	980	11	4	3	3	630

The letter X in the 'Enclosure Type' code should be replaced with the number 7 or 8 depending on the size of enclosure required.

If cables greater than 300mm² are being used it is advisable to use the SX8 size enclosure.

7 refers to an SX7 size enclosure measuring:
650 x 950 x 300mm

8 refers to an SX8 size enclosure measuring:
800 x 1250 x 300mm

Other sizes of enclosures are available to special order.



ABTECH HVJB RANGE

Shown below are some examples of the arrangements shown in the table on the previous page. For details on the enclosure please see the SX range for dimensions and specification.

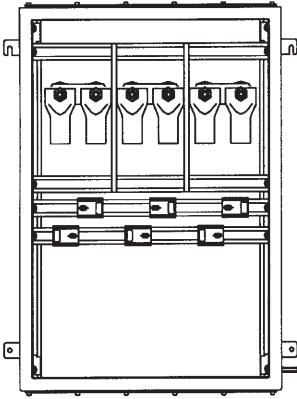

HVJB X3(0-2)
Cables entering from bottom only.

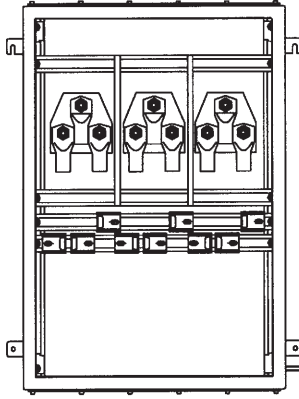

HVJB X3(0-3)
Cables entering from bottom only.

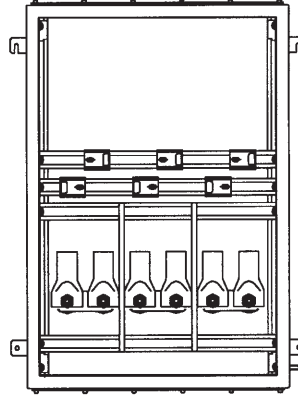

HVJB X3(2-0)
Cables entering from top only.

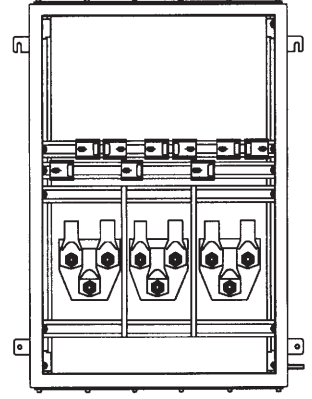

HVJB X3(3-0)
Cables entering from top only.

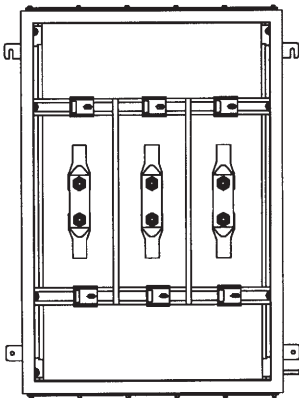

HVJB X3(1-1)
Cables entering from top & bottom.

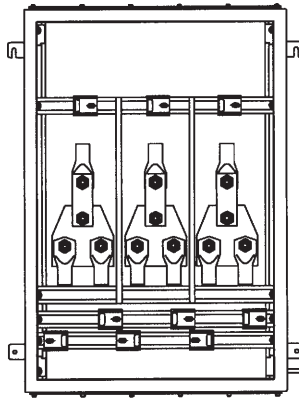

HVJB X3(1-2)
Cables entering from top & bottom.

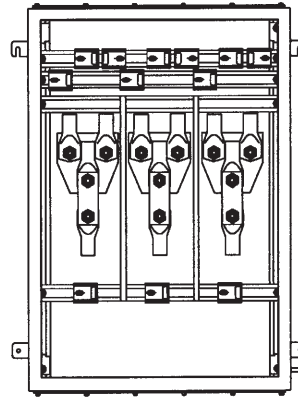

HVJB X3(2-1)
Cables entering from top & bottom.

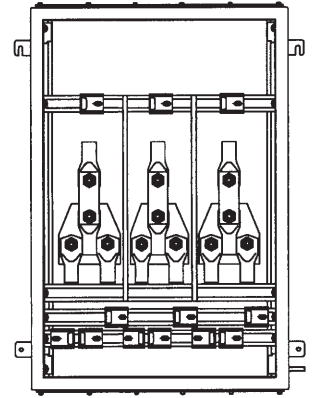

HVJB X3(1-3)
Cables entering from top & bottom.

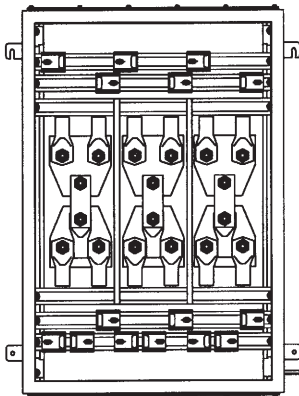

HVJB X3(2-3)
Cables entering from top & bottom.

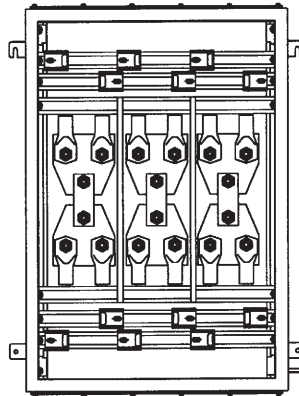

HVJB X3(2-2)
Cables entering from top & bottom.

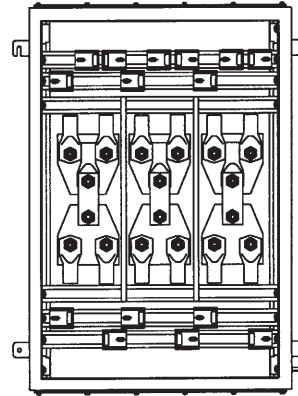

HVJB X3(3-2)
Cables entering from top & bottom.

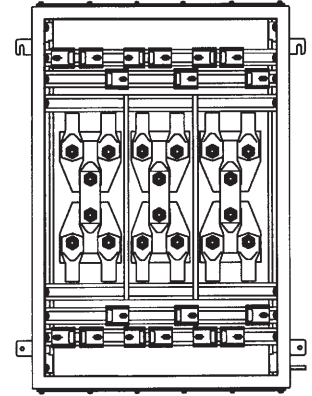

HVJB X3(3-3)
Cables entering from top & bottom.

ABTECH LR RANGE

The Abtech LR range was initially designed as a special for a particular customer but has seen increasing use by other clients due to the unique flexibility afforded by the design.

The LR range is manufactured in either mild steel or stainless steel and utilises the SX range of enclosures from SX 5 through to SX 8 all available in either 200 or 300mm depths. These are the standard sizes depending on maximum operating voltage and conductor sizes, although custom sizes can be manufactured to special order.

By using the SX design the same benefits are afforded to the LR range. These benefits include: ingress protection to IP66 as standard with IP67 available as an option, enclosure tested to the Shell/ERA deluge specification, heavy duty construction, padlock facility and internal/external earth stud fitted as standard.

All hazardous area versions are ATEX certified using the latest standards and are suitable for operation in a Category 2/Zone 1 area and Category 3/Zone 2 area.

Standard operating ambient temperature is in the range -20°C to +40°C. Versions are available which can accommodate an ambient temperature range of -50°C to +65°C.



Enclosure Type	Maximum Current (A)	Max. Voltage (kV)	Max. Ways	Maximum Conductor(mm ²)	Size (mm)
LR 52	1250	3.3	2	630	510 x 510 x 200/300
LR 73	1250	3.3	3	630	650 x 950 x 200/300

The LRJB ATEX Certification is based on the SSX5w3gp (200) and SSX7w3gp (200) enclosures. Other sizes are available on request.

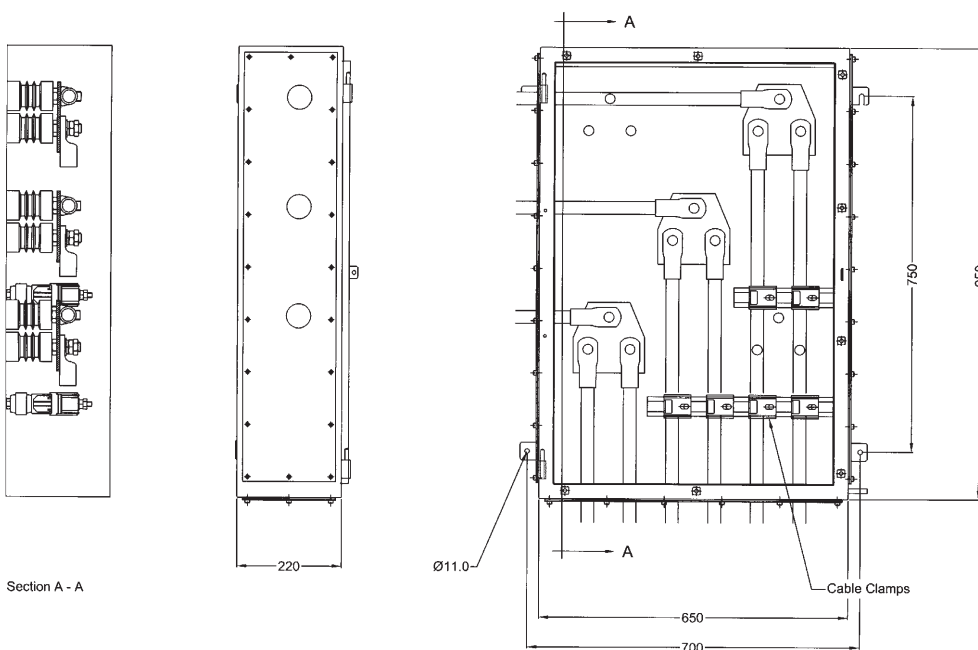

BUS - BAR RANGE

The Abtech Bus-Bar box is used for the connection of cables or equipment where the conductor size and number of cables being connected would make it very difficult in any of the other Abtech HV range. The Bus-Bar box is particularly suitable for conductor sizes over 400mm² as the design allows cables to enter the enclosure and be terminated onto the busbar without having to be bent. This makes for quick and easy installation in what could otherwise be a very difficult job. Although not based on any particular size of enclosure the Bus-Bar box utilises the SX range features and is afforded the same benefits from the use of these.

These benefits include: ingress protection to IP66 as standard with IP67 available as an option, heavy duty construction, padlock facility and internal/external earth stud fitted as standard. The Bus-Bar box incorporates heavy duty mounting which can be adapted to suit customers requirements.

The Bus-Bar box is ATEX certified using the latest standards and is suitable for operation in a Category 2/Zone 1 area and Category 3/Zone 2 area.



Enclosure Type	Maximum Current rating (A)	Max. Voltage (kV)	Max. Ways	Max. Conductors per way	Maximum Conductor (mm ²)	Max. Size (mm)
Bus-Bar Box	3000	11	4	6	1000	770 x 770 x 1250

Note:

The size detailed above is the minimum size allowable and can be increased to accommodate customer requirements.

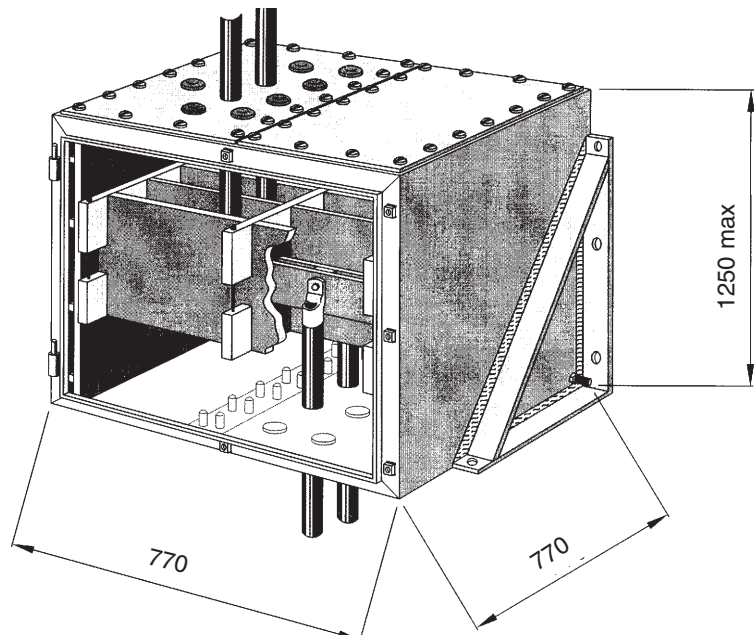
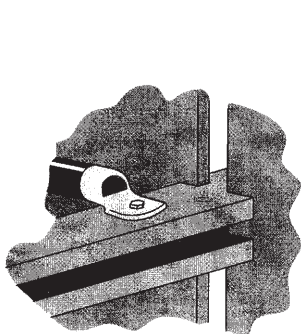

FIRE SURVIVAL

When installing essential systems such as emergency lighting or fire safety controls, great emphasis is placed on the fire survivability of the essential components such as fire dampers, actuators and cables that are contained in the area and often the specification of the junction boxes is neglected with respect to fire survival. On the basis that any system is only as good as the weakest part it is essential that attention is paid to the junction boxes being utilised for essential systems.

At Abtech we have many years experience of fire survival of junction boxes utilising both the SX and BPG ranges. We have supplied major projects world-wide with fire rated junction boxes, including, The Channel Tunnel, Dartford Tunnel and Tengiz oil refinery (Kazakhstan) to name but a few.

There are no recognised tests applicable to junction boxes and it was decided to test the enclosures to the same specification as the cable. At the time of test (1990) the two main tests for electrical cables were IEC331/1970 and BS6387/1983.

In IEC331 a cable test is conducted in which the samples are subjected to flame at a temperature of 750°C for a period of 3 hours with the electrical system being functional before, during and after the test. This test was carried out on both the SX (stainless steel) and BPG (glass reinforced polyester) ranges containing nylon, melamine and ceramic terminals. After the test it was found that the body of the nylon terminals had disappeared completely, the melamine body had taken on the appearance of biscuit (because the wood filling had burned away) and only the ceramic bodied terminal appeared to be intact. Without cleaning or disturbing the terminals in any way a flash potential of 5kV was applied between the copper conductor and the terminal rail which passed without break-down.

At Abtech it was felt that this only partly dealt with the requirements in real-life situations and it was decided to test to another cable test standard - BS6387:1987.

This test is performed in a similar way to IEC331:1970 with the specimen under test being suspended 75mm (3") above a flame, the temperature of which is maintained at 950°C for 3 hours during which the cable, and of course the junction box, is supplied with power and it must still be in working order after the test.

On the successful conclusion of this test, which is designated "fire-alone" (BS6387'C'), the next test is to mount the sample (still



powered-up) on a flat vertical surface and to apply flame at a temperature of 950°C (by means of a flame gun) whilst at the same time striking the board on which the sample is mounted with 25mm (1") diameter iron bar every 30 seconds for a period of 15 minutes. This is designated the impact test BS6387 'Z'.

Finally, a "fire with water test" is applied but only at a temperature of 650°C. The sample is subjected to flame at 650°C for 15 minutes after which a water spray is applied for 15 minutes and at the culmination of this test the system is required to be completely functional, this test being designated BS6387 'W'.

The SX range of enclosures passed all tests applicable to BS6387, i.e. C, Z & W however it was decided that the BPG range would only be submitted to the flame only test (C) which it passed.

In conclusion, the Abtech SX and BPG ranges when fitted with ceramic terminals are suitable for use in areas which are designated to be fitted with fire resistant cables and the type of enclosure to be used will depend on the individual circumstances of the area and advice on the correct enclosure can be sought from Abtech technical sales staff.

Enclosure Type	IEC 331 750°C/ 3 hours Flame Only	BS 6387 950°C/ 3 hours Flame Only (C)	BS 6387 950°C/ 3 hours External Impact (Z)	BS 6387 950°C/ 3 hours Water (W)
SX Range	PASS	PASS	PASS	PASS
BPG Range	PASS	PASS	N/A	N/A

TECHNICAL

ENCLOSURE SELECTION

It is vital that the enclosure selected is suitable for the application. The selection chart on page 4 can be used to help in the selection process. The enclosure should be mechanically robust enough to contain the cables and cable glands which will be fitted and the IP rating of the enclosure should be adequate to deal with the environmental conditions likely to be encountered.

The enclosure should be large enough to accommodate the terminals or components to be fitted and it should be considered at this stage whether or not future expansion will be necessary and to allow room for this. The ABTECH ENCLOSURE CALCULATOR program can be used to select the correct enclosure by quickly calculating if the required terminals will fit.

Next the cable entry points must be considered,

ie. how many and where are they to be placed. If all the cable entry points are to be on the bottom face, for instance, this may necessitate a larger enclosure than would be necessary just to accommodate the terminals.

TERMINAL SELECTION

Any terminal type or make can be fitted inside Abtech enclosures except in the case of enclosures intended for use in hazardous areas (see page number 50).

The terminal should be matched to the type and size of cable being used and attention should be paid to the current and voltage ratings of both terminal and cable. Any manufacturers instructions in relation to the fitment and necessary clearance required around the terminal should be strictly adhered to. Modular terminals can be fitted to DIN standard terminal rails and these can be fitted directly to the inside of the enclosure using the fixing points which are a standard feature of Abtech enclosures or by mounting onto a component mounting plate which is available as an option for all enclosure types and sizes.

CABLE GLANDS

Cable glands should be selected according to the cable type, screen or armour earthing requirements and the IP rating required. Using the ABTECH ENCLOSURE CALCULATOR program will quickly let you see whether your chosen enclosure can accommodate the required number of cable glands and provide a drawing automatically. Cable glands for enclosures intended for use in hazardous areas are dealt with later (see page X). Cable glands are a specialised field and the cable gland manufacturers should be contacted for technical information and help regarding correct selection of these items. Abtech can supply and fit cable glands if required or we can machine the enclosure or gland plates for fitting on site. We can provide a number of different thread forms ie. metric, NPT, PG, etc. or clearance holes.

HAZARDOUS AREAS

Abtech specialise in the design and production of junction boxes and enclosures for use in potentially hazardous areas. The SX, BPG and ZAG enclosure ranges are all certified for use in Zone 1 and Zone 2 hazardous areas.

Abtech also specialise in high voltage junction boxes for up to 11kV in Zone 1 areas and 15kV for Zone 2 areas.

The following pages give a brief guide to the protection methods used for electrical equipment in hazardous areas.

Definition

A hazardous area is defined as 'an area containing a potentially explosive atmosphere, which, if ignited, could give rise to damage of property or injury to persons'. Hazardous areas can be found in almost every industry and even in daily life, the best example being a petrol station or gas station.

Protection

How do we protect hazardous areas? i.e., how do we stop a potentially explosive atmosphere from igniting?

First, we have to understand the conditions required to cause an explosion. There are 3 conditions which must co-exist in order to create an explosion, Fuel, Oxygen and an Ignition Source. This is normally shown as the Ignition Triangle.

With this knowledge, it is possible to protect the equipment from one of the three elements required to cause an explosion. i.e. in the case of Increased Safety (EEx e) the ignition source is removed by ensuring that there are no hot surfaces or sparking components which could ignite a fuel and oxygen mixture which may enter the enclosure.

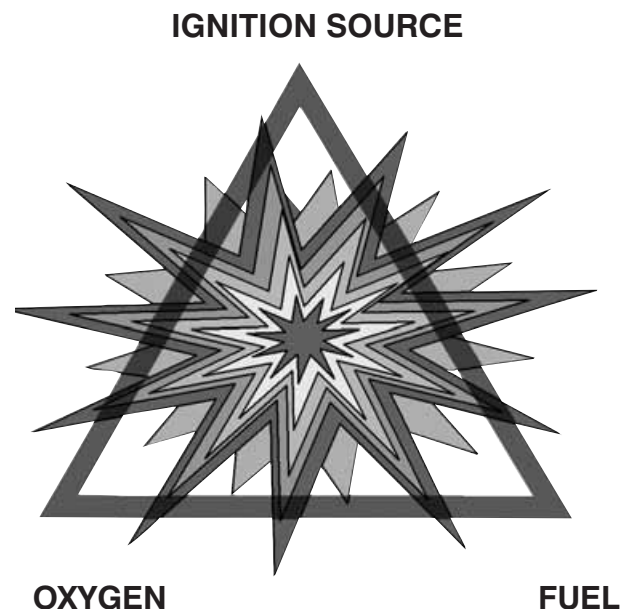

TECHNICAL

ZONE CLASSIFICATION

Codes of practise exist for the classification of areas according to the probability or likelihood of the existence of a flammable atmosphere. This is known as Area Classification and in accordance with EN 60079-14 is typically as follows on next page:

Zone 0:

Where a Flammable Atmosphere is continuously present, or present for long periods,

Typically greater than 1000 hours per year.

Permitted form of protection: Ex 'ia', Ex 's' (for Zone 0)

Zone 1:

Where a Flammable Atmosphere is likely to occur during normal operation.

Typically 10 to 1000 hours per year.

Permitted forms of protection: any type of protection suitable for Zone 0 and Ex 'd', Ex 'ib', Ex 'p', Ex 'e', Ex 's', Ex 'm', Ex 'q'.

Zone 2

Where a Flammable Atmosphere is not likely to occur during normal operation and if it does will only exist for a short period of time.

Typically less than 10 hours per year and is often referred to as the 'Remotely Hazardous Area'.

Permitted forms of protection: Any type of protection suitable for Zone 0 and 1 and Ex 'nA', Ex 'nR', Ex 'o',

TYPES OF PROTECTION

Flameproof - Ex 'd' (EN 50018)

Equipment may include arcing and sparking (or incandive) devices and flammable mixtures may enter the enclosure. The enclosure construction is designed to contain an internal explosion and prevent transmission of sufficient energy to ignite a potentially flammable atmosphere outside the enclosure.

Increased Safety - Ex 'e' (EN 50019)

Explosive mixtures may enter the equipment but the likelihood of a fault condition, which could result in ignition of this mixture, is significantly reduced. The components used in the apparatus shall not produce arcs or sparks or temperatures above that of the ignition temperature of the surrounding atmosphere in normal working conditions. Creepage and clearance distances for electrical insulation are increased over that of industrial equipment and insulation material must be reliable over long periods of time. A minimum ingress protection of IP54 must be provided by any enclosure containing increased safety equipment and it must also be capable of withstanding a 7Nm impact.

Intrinsically Safe - Ex'ia' and Ex'ib' (EN 50020)

This type of protection is afforded by the electrical

circuit or components having insufficient energy to ignite a flammable atmosphere. The protection concept is sub-divided into two groups. Ex'ia' equipment is safe under two fault conditions and permissible for use in Zone 0 Areas. Ex'ib' equipment is safe under one fault condition permissible in Zone 1 Areas. Intrinsically safe components or circuitry is normally housed in an enclosure having Ex'e' protection although this is not always necessary. In this case it is important that the integrity of the enclosure is adequate for the area of use.

Encapsulation - Ex 'm' (EN 50028)

Encapsulation of arcing and sparking components or apparatus to ensure no exposure to explosive mixtures which may be present. The surface temperature is also controlled under normal and fault conditions, thus preventing ignition from occurring.

Non Sparking - Ex 'nA' (EN 50021)

This protection method is very similar to that of Ex 'e' and although to a higher level than industrial standards it is less than that of Ex 'e'. Can only be used in Zone 2 areas but allows the use of fuses, disconnect terminals and other components not allowed in Ex 'e'.

Restricted Breathing - Ex 'nR' (EN 50021)

In this concept, protection is afforded by the sealing properties of the enclosure in which either hot or sparking equipment may be fitted. It is assumed that the likelihood of a flammable atmosphere being present whilst the enclosure is breathing is very remote and the sealing of the enclosure should be sufficient to protect against this.

Oil Immersion - Ex 'o' (EN 50015)

Where the sparking components are immersed in oil and controlled venting is also used. Most commonly found in older type switchgear.

Pressurised - Ex 'p' (EN 50016)

Pressurised or purged apparatus Type 'p' rely on a combination of a positive static pressure applied inside the enclosure and a continuous flow of air or inert gas to expel any explosive mixture which may have entered. A monitoring system is an important part of the apparatus to ensure correct operation.

Powder Filled - Ex 'q' (EN 50017)

Powder or sand filled enclosures housing arcing and sparking devices. Often used to contain the energy released from the failure of electrical or electronic components such as the breaking of a fuse.

Special - Ex 's'

No formal standard exists for this type of protection and it is the responsibility of the manufacturer and the relevant test authority to ensure that the apparatus is safe for use in the intended zone.

TECHNICAL

TEMPERATURE CLASSIFICATION & GAS GROUPINGS

Flammable mixtures can be classified under two main characteristics in respect of explosion protection; temperature of ignition by hot surfaces and the spark energy required to ignite the mixture. The spark energy of the ignition is also related to the intensity of explosion.

Classification of maximum surface temperatures in both North America and Europe are similar but vary slightly in the nomenclature used.

The temperature classification is important to ensure that the correct equipment is matched to the flammable atmospheres that could potentially exist in an area. This will take into account such things as maximum ambient temperature and maximum operating voltage with a +10% over voltage or an overload condition applied. In some types of protection such as Ex 'd' or Ex 'nR' the temperature classification is based on the outside temperature of the enclosure where as in other types of protection such as Ex 'e' or Ex 'nA' the temperature classification is based on the temperature of the internal components.

TEMPERATURE CLASSIFICATION

Maximum surface Temperature	US(NEC 505) IEC CENELEC	US (NEC 500)
450°C (842°F)	T1	T1
300°C (572°F)	T2	T2
280°C (536°F)		T2A
260°C (500°F)		T2B
230°C (446°F)		T2C
215°C (419°F)		T2D
200°C (392°F)	T3	T3
180°C (356°F)		T3A
165°C (329°F)		T3B
160°C (320°F)		T3C
135°C (275°F)	T4	T4
120°C (248°F)		T4A
100°C (212°F)	T5	T5
85°C (185°F)	T6	T6

(Unless otherwise specified on the rating plate it is assumed that the operating ambient temperature is in the range -20°C to +40°C in accordance with European standards)

All gases are grouped according to their physical properties and details of their grouping can be found in either National or International codes of practice. Some examples of Gas Groups are shown below.

GAS GROUPING FOR ELECTRICAL APPARATUS (EN 50014)

GROUP	GAS
I (Mining)	Methane (firedamp)
IIA	Industrial methane, Propane, Petrol & most industrial gases.
IIB	Ethylene, Town Gas & other industrial gases.
IIC	Hydrogen, Acetylene & Carbon Di-sulphide.

Ambient Temperature

The ambient temperature is the surrounding temperature of the environment in which the equipment is installed, whether indoors or outdoors. For electrical equipment certified in Europe it is assumed that the ambient temperature in which the equipment may be operated is between -20°C and +40°C. Some types of equipment are certified for operation outwith this range and if so must be stated on the equipment label or certificate.

NORTH AMERICAN STANDARDS

In North America all electrical installations are governed by the National Electric Code (NEC). Electrical equipment used in ordinary, wet and hazardous (or classified) locations must be 'listed' by an accredited approval agency for use in the intended location. The hazardous locations include areas in which flammable, combustible or ignitable substances may occur in hazardous quantities. The NEC codes use a different way of categorising the hazardous locations, which is by Class and Division, compared with the European and IEC standards, which have adopted the Zonal method. Electrical apparatus approved in North America for use in hazardous locations must be categorised with an Equipment Class and suitable for a specified Division and Gas Group. Classifications are made in line with the amount of combustible materials as follows:-

- Class I - Flammable gases, vapours or mists
- Class II - Combustible dusts
- Class III - Ignitable fibres and flyings

A comparison of zones and divisions is shown in the picture below.

In 1996 article 505 was introduced to the NEC which allowed zonal classification of hazardous areas. This now means that products can be approved as follows:

either,

Class, Division & Gas Group,

e.g. Class I, Division 2, A,B,C,D

or

Class, Zone & Gas Group

e.g. Class 1, zone 2, IIA,IIB,IIC

TECHNICAL

Although this code change permits the use of products that have a Zonal classification, in a similar way to European practice, mixing of different forms of equipment approval across zones or divisions is not acceptable, e.g. products approved for Zone I do not necessarily meet the requirements of Division I, which also encompasses Zone 0.

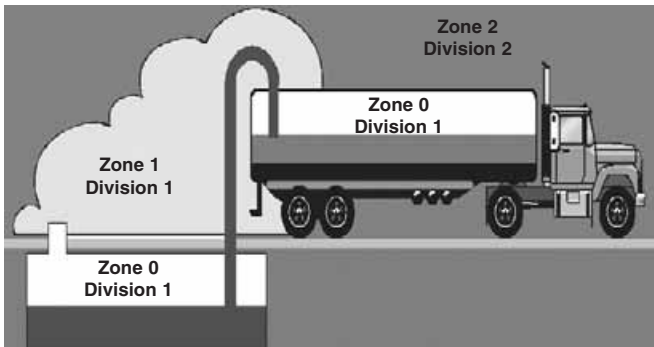

Although no direct equivalents exist between European/IEC and American codes of protection and Area Classification there are similarities and there is a developing acceptance of European/IEC methods in North America and vice versa.

The table below shows the basic relationships between the North American and European classifications.

Equivalent Division/Zone

NEC	European/IEC
Division I	Zone 0 Zone 1
Division II	Zone 2

As can be seen from the table above, Division I covers both the European/IEC Zones 0 & 1. Therefore, care must be taken when using zone classified equipment in a Division 1 area as to the suitability of the protection employed.

Underwriters Laboratory (UL) and Factory Mutual Inc (FM) are the two main certification bodies in North America and in some cases, electrical equipment may also need to meet certain Marine Standards, and be separately approved by the US Coast Guards, before it can be used e.g. on an offshore oil rig.

INGRESS PROTECTION

A major secondary protection parameter is the ingress protection of the electrical equipment. Moisture or dust if allowed to come into contact with electrical circuits could lead to either sparking or physical breakdown of the components and interfere with the protection method being used. In some cases the IP rating forms part of the explosion protection method. All IP ratings for products in this catalogue have been carried out in accordance with EN 60529 (IEC 529) and have been witness tested by independent

test laboratories. It will be noted that some products have both IP66 and IP67 ratings and this is because in some instances the IP66 requirement is more onerous than the IP67 requirement.

Both the SX range and BPG ranges have also been tested to the Shell/ERA deluge specification. This is one of the most onerous water ingress tests and was designed specifically for electrical equipment which would be subject to deluge conditions, e.g. Ships decks, fire deluge areas.

The following table shows the criteria for IP requirements to EN 60529(IEC 529)

First Digit	Degree of Protection (Dust)	Second Digit	Degree of Protection (Dust)
0	No protection	0	No protection
1	Protection against ingress of large solid particles	1	Protection against ingress of vertically dripping water
2	Protection against ingress of medium sized solid particles	2	Protection against ingress of water dripping at an angle of 75° to 90°
3	Protection against ingress of solid particles greater in thickness than 2.5mm	3	Protection against ingress of sprayed water
4	Protection against ingress of small solid foreign bodies greater in thickness than 1mm	4	Protection against ingress of splashed water
5	Protection against ingress of dust in an amount sufficient to interfere with enclosed equipment	5	Protection against ingress of water jets
6	Complete protection against ingress of dust	6	Protection against ingress of water in heavy seas
		7	Protection against effects of temporary immersion
		8	Protection against effects of indefinite immersion

ATEX DIRECTIVE

The ATEX directive started its transition period of implementation in March 1996 and will be mandatory by July 2003. All of the products in this catalogue have an EC type examination certificate to the ATEX directive. ATEX covers both electrical and mechanical ignition hazards.

Apparatus is divided into Equipment groups (I for mining and II non-mining), source of ignition Gas (G) and Dust (D) and Categories 1, 2 and 3. The Categories provide respectively, very high, high and normal levels of protection against ignition. The Categories will deliver the level of protection which is currently obtained by applying the existing protection techniques (Ex d, Ex e etc.), and also will take into account other protection concepts proposed by manufacturers and considered by the Notified (certification) bodies who will produce EC type examination (ATEX) certificates.

The Categories in practice are equated to suitability for Zones. The actual category of apparatus specified for a Zone will depend on the overall risk assessment for a Zone. The Zoning considers only the probability of the existence of an explosive atmosphere. It does not consider the consequential effects of an ignition taking place. Apparatus will be marked with the grouping and Category in addition to the marking required by the individual protection standards.

TECHNICAL

All Abtech products are certified for use in group II, industrial applications, most are certified for both Gas (G) and Dust (D) hazards and are suitable for classification in Categories 2 and 3. This means that they are or will generally be suitable for use in Zone 1 and 2 areas. Guidance is given by the codes of practice such as EN 60079-10 and EN 60079-14 etc. These codes of practice provide the user with guidance in selecting apparatus to obtain the degree of safety that is required for the particular hazardous area application.

An EC type examination by a notified body is required for Category 1 and 2 equipment but not for Category 3 where certification is supplied by the manufacturer.

JUNCTION BOXES IN HAZARDOUS AREAS

Junction boxes and terminal enclosures for use in hazardous areas mainly contain non incandive devices, i.e. terminals. For Ex 'e' certified apparatus there are two main criteria when specifying the apparatus.

1. Are the components acceptable for use in the enclosure, i.e. non sparking, and,
2. Will any components or wiring be hotter than the temperature classification of the apparatus allows.

To comply with the first requirement, only terminals or other components which are specifically allowed for in the certificate of compliance may be fitted. That means that only component certified terminals may be fitted, and after June 2003 when the transition period for ATEX ends, only ATEX certified components may be fitted. (Apparatus constructed prior to July 2003 need not meet this requirement).

To ensure compliance with the second criteria for safe use, all low voltage Abtech enclosures are certified using the dissipated power method.

Through testing it has been determined what the maximum power dissipation can be from the components and wiring inside each enclosure size to ensure that the temperature of any of the components does not exceed the temperature classification of the apparatus.

This figure is shown for each of the products throughout the catalogue and can be found on each of the product certificates.

By knowing the total current through the enclosure and the total resistance of the terminals and wiring, using Ohms law it is possible to calculate the dissipated power of the circuit.

The resistance of the terminals can be sought from the terminal manufacturers and the resistance of the conductors is available in reference books or from the cable manufacturers.

Power dissipation $W = I^2 R$

where: I is the total current through the enclosure, and
 R is the total resistance of the terminals and conductor contained within the enclosure.

A much easier and simpler way of working out the above is to use the Abtech '**Box Calculation Program**'.

This simple program can calculate the maximum power dissipation of the enclosure and will also provide a drawing with the information contained in it.

The program will also calculate a cable entry matrix. The program which will operate with Microsoft Windows 95/98/2000 can be obtained free of charge by contacting Abtech on any of the numbers or email addresses on the back page of the catalogue or from the web site at www.ab-tech.co.uk.

In all Ex certified enclosures it is important that an earth facility is provided. In plastic enclosures this may be by means of an internal/external earth stud or by an earth terminal fitted inside. Additional earthing for cable glands can be provided by an earth continuity plate fitted inside the enclosure wall. For metallic enclosures the earth facility must earth the enclosure body and can be provided by earth terminals connected to the body through the terminal mounting rail and/or by means of an internal/external earth stud.

Plastic enclosures carry a risk of static discharge which could lead to a spark being produced if rubbed with a dry cloth. Plastic enclosures should only ever be cleaned using a damp cloth. Optionally, plastic enclosures with a graphite filling is available which reduces this risk.

CABLE GLANDS FOR USE IN HAZARDOUS AREAS

Cable glands used in enclosures intended for use in a hazardous area must meet the same criteria as the enclosure to which they are connected.

For example, cable glands used on an EEx 'e' enclosure must meet the requirements for enclosures of the EEx 'e' standard i.e. must be capable of withstanding a 7Nm impact and capable of maintaining an ingress protection of at least IP54. If a plastic or non metallic cable gland is used it must be capable of passing these tests after having undergone an accelerated conditioning period.

Most reputable cable gland manufacturers have their products approved by a suitably notified body and will carry the certification markings on the body of the gland.

Cable glands are a very important element in the protection of electrical equipment and should not be underestimated. There are a vast array of different cables in use today and it is important that advice is sought from a cable gland manufacturer regarding selection.



**GOST R
ATEX**



**BS EN
ISO 9002**



ABTECH PROJECTS

Major Projects Worldwide

Abu Dhabi	ADNOC 545 Project, ADNOC Bab-Maqta-Taweelah, Gas Pipeline Project, Adma Opca MODICS Project.
Algeria	Sonatrach Project
Brunei	Shell
Canada	Hibernia, Sable, Terra Nova
China	Bohai Oil Phase 1 & 2, Panyu
Dubai	Dugas
India	ONGC ICP Project, ONGC ICW Project
Indonesia	Marathon Oil Kakap Project Line
Iran	Khorasan Project
Malaysia	KVCM Project
Qatar	North Field Development Project, RasGas
Saudi Arabia	Aramco GOSP 4
Singapore	ACT-OG-32 Project, Total Bongkot Field Development Project
Taiwan	FPC Upgrade
Thailand	Thai Petroleum - Thapp
U.A.E.	Zadco

European Offshore

AGIP	Tiffany
Amerada Hess	Rob Roy, Ivanhoe, Scott, Triton
Britoil/BP	Beatrice, Thistle, Clyde
British Gas	Morecambe Bay, Phases 1 & 2, Morecambe Bay Onshore Roughs Project, Armada.
BP	ULA (Norway), South East Forties, Wytch Farm, Miller Bruce, Andrew, Cleeton, Azeri, Clair
Chevron	Alba
Conoco	Murchison, Hutton, Complete Southern Basin Development, Caister/Murdoch Development, Heidrun
Hamilton	Esmond, Duncan, Ravenspurn North, Liverpool Bay
Mobil	Beryl 'B', Beryl 'A' Refit
Norsk Hydro	Oseberg 2
Occidental Petroleum	Claymore, Piper 'B', Saltire
Petroleum Shell	Tern, Eider, Sole Pit, Kittiwake, Gannet, Galleon, Pelican Captain, Bonga
Total	North Alwyn 'A' and 'B', St. Fergus Terminal

UK

Saltash Tunnel
Blackwall Tunnel
Birmingham Northern Relief Road
Alternative Landing Ship Logistic Vessels

The above list represents some of the major projects that Abtech have been involved in over the years. This is only a portion of works undertaken and Abtech continue to be a provider of quality equipment to many projects and industries world-wide.

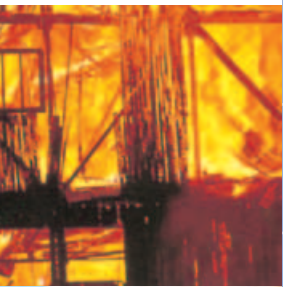

NOVAMAX INTL LLC - 8200 S Quebec St Suite A-3 Englewood, CO 80112
(303) 470-7226 Fax (303) 470-5773 Toll-Free 1-800-594-3380
www.novamaxinternational.com